

**ADEMCO VISTA SERIES**  
**VISTA-20P / VISTA-20PSIA**  
**VISTA-15P / VISTA-15PSIA**  
**Security Systems**

**Programming Guide**

# RECOMMENDATIONS FOR PROPER PROTECTION

## The Following Recommendations for the Location of Fire and Burglary Detection Devices Help Provide Proper Coverage for the Protected Premises.

### Recommendations For Smoke And Heat Detectors

With regard to the number and placement of smoke/heat detectors, we subscribe to the recommendations contained in the National Fire Protection Association's (NFPA) Standard #72 noted below.

Early warning fire detection is best achieved by the installation of fire detection equipment in all rooms and areas of the household as follows: For minimum protection a smoke detector should be installed outside of each separate sleeping area, and on each additional floor of a multi-floor family living unit, including basements. *The installation of smoke detectors in kitchens, attics (finished or unfinished), or in garages is not normally recommended.*

For additional protection the NFPA recommends that you install heat or smoke detectors in the living room, dining room, bedroom(s), kitchen, hallway(s), attic, furnace room, utility and storage rooms, basements and attached garages.

In addition, we recommend the following:

- Install a smoke detector inside every bedroom where a smoker sleeps.
- Install a smoke detector inside every bedroom where someone sleeps with the door partly or completely closed. Smoke could be blocked by the closed door. Also, an alarm in the hallway outside may not wake up the sleeper if the door is closed.

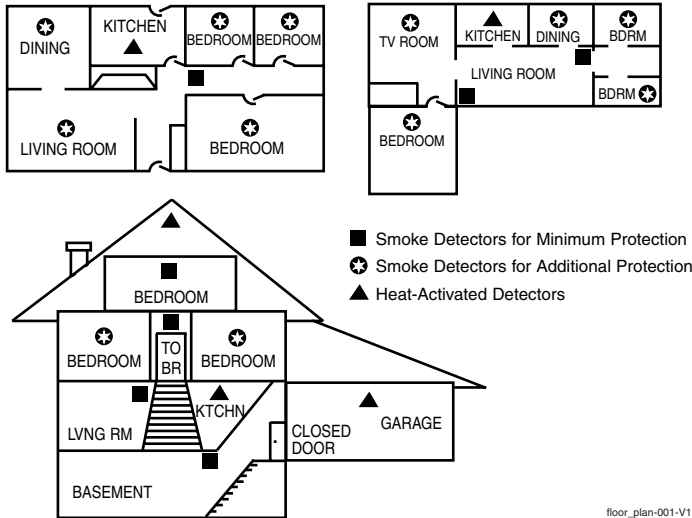

- Install a smoke detector inside bedrooms where electrical appliances (such as portable heaters, air conditioners or humidifiers) are used.
- Install a smoke detector at both ends of a hallway if the hallway is more than 40 feet (12 meters) long.
- Install smoke detectors in any room where an alarm control is located, or in any room where alarm control connections to an AC source or phone lines are made. If detectors are not so located, a fire within the room could prevent the control from reporting a fire or an intrusion.

**THIS CONTROL COMPLIES WITH NFPA REQUIREMENTS FOR TEMPORAL PULSE SOUNDING OF FIRE NOTIFICATION APPLIANCES.**

### Recommendations For Proper Intrusion Protection

For proper intrusion coverage, sensors should be located at every possible point of entry to a home or commercial premises. This would include any skylights that may be present, and the upper windows in a multi-level building.

In addition, we recommend that radio backup be used in a security system so that alarm signals can still be sent to the alarm monitoring station in the event that the telephone lines are out of order (alarm signals are normally sent over the phone lines, if connected to an alarm monitoring station).

## TABLE OF CONTENTS

PROGRAMMING MODE COMMANDS .....	4
DATA FIELD PROGRAMMING FORM .....	5
CONFIGURABLE ZONE TYPES WORKSHEET .....	18
*56 ZONE PROGRAMMING MENU MODE .....	19
*58 EXPERT ZONE PROGRAM MODE .....	21
WIRELESS KEY PROGRAMMING TEMPLATES.....	22
*57 FUNCTION KEY PROGRAMMING MENU MODE .....	24
OUTPUT DEVICE PROGRAMMING GENERAL INFORMATION (*79/*80 Menu Mode) .....	25
*79 RELAY/POWERLINE CARRIER DEVICE (X-10) PROGRAMMING MENU MODE.....	25
*80 OUTPUT FUNCTION MENU MODE .....	26
*81 ZONE LIST MENU MODE.....	28
*82 ALPHA DESCRIPTOR MENU MODE .....	29
ALPHA VOCABULARY LIST (For Entering Zone Descriptors) .....	31
SETTING SCHEDULES .....	32
AVS SYSTEM ENABLE and QUICK PROGRAMMING COMMANDS .....	33
SETTING THE REAL-TIME CLOCK.....	33
*29 COMMUNICATION DEVICE MENU MODE (Pass-Through Programming).....	34
UPLOADING/DOWNLOADING VIA the INTERNET .....	35
ZONE TYPE DEFINITIONS.....	36
REPORT CODE FORMATS.....	37
SYSTEM SECURITY CODES .....	38
KEYPAD FUNCTIONS .....	39
COMPATIBLE DEVICES.....	39
VARIOUS SYSTEM TROUBLE DISPLAYS.....	40
UL NOTICES .....	41
SIA QUICK REFERENCE GUIDE .....	41
ULC S304 REQUIREMENTS (for VISTA-15PCN and VISTA-20PCN).....	41
FCC STATEMENTS .....	42
LIMITATIONS STATEMENT .....	43
CONTACTING TECHNICAL SUPPORT .....	43
WORKSHEET for *56 ZONE PROGRAMMING.....	44
WORKSHEET for *57 FUNCTION KEY PROGRAMMING.....	45
WORKSHEET for *79 OUTPUT RELAY/POWERLINE CARRIER DEVICE PROGRAMMING .....	45
WORKSHEET for *81 ZONE LIST PROGRAMMING.....	45
<input type="checkbox"/> WORKSHEET for *80 OUTPUT FUNCTION PROGRAMMING .....	46
WORKSHEET for SCHEDULES.....	47
TABLE OF DEVICE ADDRESSES.....	47
5800 SERIES TRANSMITTER INPUT LOOP IDENTIFICATION .....	48

## PROGRAMMING MODE COMMANDS

**Compatibility:** This document applies to systems with microprocessor version 9.1 or higher.

**TO ENTER PROGRAMMING MODE** (using an alpha keypad connected to the control):

- A. POWER UP, then press **[\*]** and **[#]** at the same time, within 50 seconds of powering up (this method must be used if **\*98** was used to exit program mode). **OR**  
 B. Enter **Installer Code** (4112) then **8 0 0**.

### PROGRAMMING COMMANDS

Task	Command/Explanation
<b>Go to a Data Field</b>	<b>Press [*] + [Field Number], followed by the required entry.</b>
<b>Entering Data</b>	When the desired field number appears, simply make the required entry. When the last entry for a field is entered, the keypad beeps three times and automatically displays the next data field in sequence. If the number of digits that you need to enter in a data field is less than the maximum digits available (for example, the phone number fields *41, *42), enter the desired data, then press [*] to end the entry. The next data field number is displayed.
<b>Review a Data Field</b>	<b>Press [#] + [Field Number].</b> Data will be displayed for that field number. No changes will be accepted in this mode.
<b>Deleting an Entry</b>	<b>Press [*] + [Field Number] + [*].</b> (Applies only to fields *40 thru *46, *94, and pager fields)
<b>Initialize Download ID</b>	<b>Press *96.</b> Initializes download ID and subscriber account number.
<b>Reset Factory Defaults</b>	<b>Press *97.</b> Sets all data fields to original factory default values.
<b>Zone Programming</b>	<b>Press *56.</b> Zone characteristics, report codes, alpha descriptors, and serial numbers for 5800 RF transmitters.
<b>Function Key Programming</b>	<b>Press *57.</b> Unlabeled keypad keys (known as ABCD keys) for special functions
<b>Zone Programming (Expert Mode)</b>	<b>Press *58.</b> Same options as *56 mode, but with fewer prompts. Intended for those familiar with this type of programming, otherwise *56 mode is recommended.
<b>Output Device Mapping</b>	<b>Press *79.</b> Assign module addresses and map individual relays/powerline carrier devices
<b>Output Programming</b>	<b>Press *80.</b> 4229 or 4204 Relay modules, Powerline Carrier devices, or on-board triggers
<b>Zone List Programming</b>	<b>Press *81.</b> Zone Lists for relay/powerline carrier activation, chime zones, pager zones, etc.
<b>Alpha Programming</b>	<b>Press *82.</b> Zone alpha descriptors
<b>IP/GSM Programming</b>	<b>Press *29.</b> For programming the IP/GSM options.
<b>Exit Program Mode with installer code lockout</b>	<b>Press *98.</b> Exits programming mode and <i>prevents</i> re-entry by: Installer Code + 8 0 0. To reenter programming mode, the system must be powered down, then powered up. Then use method A above. See field *88 for other *98 Program mode lockout options.
<b>Exit Program Mode</b>	<b>Press *99.</b> Exits program mode and <i>allows</i> re-entry by: Installer Code + 8 0 0 or method A above.
<b>Scheduling Mode</b>	<b>Enter code + [#] + 64.</b> Create schedules to automate various system functions.
<b>Site-Initiated Download</b>	<b>Installer code + [#] + 1</b> (perform while system is disarmed and in normal mode)

### AVS QUICK PROGRAMMING COMMANDS (for AAV sessions using the AVS system)

For controls with the following firmware revision levels, these commands automatically configure the control for AVS operation. VISTA-15P = version 6.0 or higher; VISTA-20P = version 7.0 or higher

- **installer code + [#] + [0] + 3:** enable AVS operation
  - **installer code + [#] + [0] + 4:** enable AVS operation and enable panels sounds on the AVST speaker
  - **installer code + [#] + [0] + 5:** remove all programming options set by [#] + [0] + 3 quick command
  - **installer code + [#] + [0] + 6:** remove all programming options set by [#] + [0] + 4 quick command
- Refer to the AVS SYSTEM ENABLE and QUICK PROGRAMMING COMMANDS section for details on the specific options that are set with each command, depending on the control used.

To select the AAV session communication path (phone line/communication device), see field \*55 Dynamic Signaling Priority. To enable AAV operation, use \*91 Options field (option 4).

### TO ENABLE REMOTE SERVICES

1. Enable the Remote Interactive Services (RIS) option in programming field \*91 (entry 2).
2. Use programming field \*189 to enable a remote services emulated keypad address.
3. Use \*29 Menu mode to enable the communication device.
4. If using Total Connect 2.0, use AlarmNet Direct website to program the communicator and enable TC2 services. Be sure to "send" the programming data down to the Communicator.

**IMPORTANT: The Real-Time Clock** must be set before the end of the installation. See procedure in the Setting the Real-Time Clock section of this manual.

### SPECIAL PROGRAMMING MESSAGES

- **OC** = OPEN CIRCUIT (no communication between Keypad and Control).
- **EE** or **ENTRY ERROR** = ERROR (invalid field number entered; re-enter valid field number).
- After powering up, **AC**, **dl** (disabled) or **"Busy Standby vx.x** (firmware revision) **DI** will be displayed after approximately 4 seconds. This will revert to a **"Ready"** message in approximately 1 minute, which allows PIRS, etc. to stabilize. You can bypass this delay by pressing [#] + [0].  
**NOTE for CANADIAN PANELS:** Power up time is 2 minutes, and Contact ID report code 305 System Reset is sent if the [#] + [0] command is not performed before the 2 minutes expires.
- If **E4** or **E8** appears, more zones than the expansion units can handle have been programmed. The display will clear after you correct the programming.

## DATA FIELD PROGRAMMING FORM

Entries apply to the ADEMCO VISTA-15P/VISTA-15PSIA and ADEMCO VISTA-20P/VISTA-20PSIA controls, except entries shown in dashed boxes, which apply only to the VISTA-20P/VISTA-20PSIA (partition entries) and are not applicable to the VISTA-15P/VISTA-15PSIA. In addition, where noted, certain fields have special settings when used with the SIA panels (indicated by **V20PSIA/V15PSIA** with heavy borders and reverse type throughout for easy identification). Entry of a number other than one specified will give unpredictable results. Values shown in brackets are factory defaults. **SIA Guidelines:** Notes in certain fields give instructions for programming the VISTA-20P/VISTA-15P for False Alarm Reduction.

**SIA Installations:** The VISTA-20PSIA and VISTA-15PSIA are certified SIA-compliant controls that meet SIA specifications for False Alarm Reduction. The other controls described in this manual are not certified as SIA compliant, but can be programmed for False Alarm Reduction. To program for False Alarm Reduction, follow the SIA Guidelines noted in the applicable programming fields.

<b>*20</b>	<b>Installer Code</b> Enter 4 digits, 0000-9999	<input type="text"/> <input type="text"/> <input type="text"/> <input type="text"/> [4112]
		<p>The Installer Code is used to assign the 4-digit Master Security Code. The Installer Code can perform all system functions except it cannot disarm the system unless it was used to arm the system. For security purposes, the factory default installer code should be changed.</p>
<b>*21</b>	<b>Quick Arm Enable</b> 0 = no 1 = yes	<input type="checkbox"/> <input type="checkbox"/> [0,0] Part. 1    Part.2 If enabled, users can press the [#] followed by an arming key to arm the system instead of using a security code. The security code is always needed to disarm the system.
<b>*22</b>	<b>RF Jam Option</b> 0 = no RF Jam detection 1 = send RF Jam report	<input type="checkbox"/> [0] If enabled, a report is sent if the system detects an RF jamming signal. <u>UL: must be 1 if wireless devices are used</u>
<b>*23</b>	<b>Quick (Forced) Bypass</b> 0 = no quick bypass 1 = allow quick bypass (code + [6] + [#] )	<input type="checkbox"/> <input type="checkbox"/> [0,0] Part. 1    Part. 2 Zones bypassed by this function will be displayed after the bypass is initiated. <u>UL: must be 0</u>
<b>*24</b>	<b>RF House ID Code</b> 00 = disable all wireless keypad use 01-31 = using 5827, 5827BD or 5804BD keypad	<input type="text"/> <input type="text"/> <input type="text"/> <input type="text"/> [00,00,00] P1    P2    Common The House ID identifies receivers and wireless keypads. If a 5827 or 5827BD Wireless Keypad or 5804BD Transmitter is being used, a House ID code <b>must</b> be entered and the keypad set to the same House ID. You can assign RF house ID for each partition
<b>*26</b>	<b>Chime By Zone / KP Sound Enables</b> <b>Entry 1</b> 0 = no "entry 1" keypad trouble sounds, AND no chime by zone (keypad chimes on fault of any entry/exit or perimeter zone when chime mode is on) 1 = Chime by Zone enabled 2 = Communication Device (LRR) trouble sounding enabled (for communication devices such as GSMV4G, GSMX4G, IGSMV4G) 4 = System Low Battery sounding enabled 7 = select all entry 1 options  <b>Entry 2</b> 0 = no "entry 2" keypad trouble sounds 1 = RF Supervision sounding enabled 2 = RF Low Battery sounding enabled 4 = RF Jam sounding enabled 7 = select all entry 2 options	<input type="checkbox"/> <input type="checkbox"/> [6, 7] 1    2 <b>Chime by Zone</b> If Chime by Zone is enabled (entry 1 – option 1), you can define the specific zones intended to chime when faulted while the system is in Chime mode. List chime zones on zone list 3 using *81 Menu mode. <b>Keypad (KP) Trouble Sounding</b> Keypad trouble sounding can be enabled/disabled for the conditions listed for each entry.  For each entry, enter the sum of the desired options. Example Entry 1: for Chime by Zone and System Low Battery sounding, enter 5. To enable all options, enter 7.
<b>*27</b>	<b>Powerline Carrier Device (X-10) House Code</b> 0 = A    6 = G    #11 = L 1 = B    7 = H    #12 = M 2 = C    8 = I    #13 = N 3 = D    9 = J    #14 = O 4 = E    #10 = K    #15 = P 5 = F	<input type="checkbox"/> [0] Powerline Carrier devices require a House ID, identified in this field. Program Powerline Carrier devices in interactive modes *79, *80 and *81. <u>UL: not for fire or UL installations</u>

**\*28**

**Access Code For Phone Module**

00 = disable  
1st digit: enter 1-9  
2nd digit: enter # + 11 for "\*", or # + 12 for "#".

[00]

(Partition 1 only)

You must assign a 2-digit access code for the 4286 Phone Module, if used. Example: If desired access code is 7\*, then 7 is the first entry, and [#] + 11 (for \*) is the second entry.

**NOTE:** A 0 in either digit disables the phone module.

UL: must be 00 for UL Commercial Burg. installations

**\*29 Enable IP/GSM? – Communication Device Menu Mode (pass-through programming)**

This is a Menu Mode command, not a data field, for programming IP/GSM communication device options. See \*29 Menu Mode section later in this document.

**\*31**

**Single Alarm Sounding Per Zone**

0 = unlimited sounding  
1 = one alarm sounding per zone

[0]

If enabled, limits alarm sounding on the bell output to once per zone per armed period.

**V20PSIA/V15PSIA:** If "0" selected, "alarm sounding per zone" will be the same as the "number of reports in armed period" set in field \*93 (1 if one report, 2 if 2 reports, unlimited for zones in zone list 7).

**\*32**

**Fire Alarm Sounder Timeout**

0 = sound stops at timeout selected in field \*33  
1 = no timeout; sounds until manually turned off

[0]

This control complies with NFPA requirements for temporal pulse sounding of fire notification appliances. Temporal pulse sounding for a fire alarm consists of the following: 3 pulses – pause – 3 pulses – pause – 3 pulses.

UL: must be 1 for fire installations

**\*33**

**Alarm Sounder (Bell) Timeout**

0 = none                    3 = 12 min  
1 = 4 min                    4 = 16 min  
2 = 8 min

[1]

This field determines whether the external sounder (and keypad sounder) will shut off after time allotted, or continue until manually turned off.

UL: For residential fire alarm installation, must be set for a minimum of 4 min (option 1); for UL Commercial Burglary installations, must be minimum 16 min (option 4)

**\*34**

**Exit Delay**

00 - 96 = 0 - 96 secs  
97 = 120 secs

[60,60]

Part. 1    Part. 2

The system waits the time entered before arming entry/exit zones. If the entry/exit door is left open after this time expires, an alarm will occur. Common zones use same delay as partition 1.

SIA Guidelines: minimum exit delay is 45 seconds

Common zones use part. 1 delay.

UL installations: For UL Commercial Burglar Alarm and UL Residential Burglar Alarm installations with line security, total exit time must not exceed 60 seconds.

**V20PSIA/V15PSIA:**  
45 - 96 = 45 - 96 secs; 97 = 120 secs  
NOTE: Entries less than 45 will result in a 45-second delay.

**\*35**

**Entry Delay #1**

00 - 96 = 0 - 96 seconds  
97 = 120 secs  
98 = 180 secs  
99 = 240 secs

[30,30]

Part. 1    Part. 2

Upon entering, the system must be disarmed before the time entered expires, otherwise it sounds an alarm.

Common zones use same delay as part 1.

SIA Guidelines: minimum entry delay is 30 seconds

For UL Residential Burglary Alarm installations, must be set for a maximum of 30 seconds; entry delay plus dial delay should not exceed 1 min. For UL Commercial Burglar Alarm, total entry delay may not exceed 45 seconds. Upon entering, the system must be disarmed before the time entered expires, otherwise it sounds an alarm.

**V20PSIA/V15PSIA:**  
30-96 = 30 - 96 secs; 97 = 120 secs;  
98 = 180 secs; 99 = 240 secs  
NOTE: Entries less than 30 will result in a 30-second delay.

**\*36**

**Entry Delay #2**

See \*35 Entry Delay 1 for entries.

[30,30]

Part. 1    Part. 2

**\*37**

**Audible Exit Warning**

0 = no; 1 = yes

[1,1]

Part. 1    Part. 2

Warning sound consists of slow continuous beeps until the last 10 seconds, and then it changes to fast beeps. Sound ends when exit time expires.

SIA Guidelines: must be enabled

**V20PSIA/V15PSIA:** Feature always enabled; field does not exist.

**\*38**

**Confirmation Of Arming Ding**

0 = no  
1 = yes (wired keypads and RF)  
2 = yes, RF only (except 5827, 5827BD)

[0,0]

Part. 1 Part. 2

Confirmation of arming is 1/2-sec external sounder "ding."  
If 1 selected, ding occurs when closing report is sent if open/close reporting is enabled, or at the end of Exit Delay. If 2 selected, ding occurs upon reception of the wireless arming command.

**V15P/V15PSIA NOTE:** This option applies only to the Telco reporting path (not for communication device).

UL: must be 1 for UL Commercial Burglar Alarm inst.

**\*39**

**Power Up In Previous State**

0 = no, always power up disarmed;  
1 = yes, power up in previous state

When the system powers up armed, an alarm will occur 1 minute after arming if a zone is faulted. Note that if the previous state was armed Away or Stay, the system ignores sensor changes for 1 minute, which allows sensors such as PIRs to stabilize.

UL: must be 1

SIA Guidelines: must be 1

**V20PSIA/V15PSIA:** Feature always enabled; field does not exist.

**DIALER PROGRAMMING (\*40 – \*42)**

Do not fill unused spaces. Enter 0–9; #+11 for '\*'; #+12 for '#'; #+13 for a 2-second pause. If fewer than the maximum digits entered, exit the field by pressing [\*]. The next data field number is displayed.

**\*40**

**PABX Access Code or Call Waiting Disable**

Enter up to 6 digits.  
To clear entries, press \*40\*.  
If call waiting is used, enter call waiting disable digits "\* (#+11) 70" plus "# + 13" (pause).

| | | | | |

**Call Waiting:** If the subscriber's phone service has "call waiting" (and is not using PABX), enter "\*\*70" ("# + 11") plus "# + 13" (pause) as the PABX entry to disable "call waiting" during control panel calls. If the subscriber does not have "call waiting" and is not using PABX, make no entry in this field.

**NOTES:**

- 1. The call waiting disable feature cannot be used on a PABX line.
- 2. Using Call Waiting Disable on a non-call waiting line will prevent successful communication to the central station.

**V20PSIA/V15PSIA:** If call waiting is used, enter call waiting disable digits as described above, and also set Call Waiting Disable option in field \*91.

**\*41**

**Primary Phone No.**

| | | | | | | | | | | | | | | | | | | | | |

**\*42**

**Secondary Phone No.**

| | | | | | | | | | | | | | | | | | | | | |

Enter up to 20 digits. To clear entries, press \*41\* or \*42\* respectively. Enter the respective phone numbers.

**\*43**

**Partition 1 Primary Acct. No.**

| | | | / | | | | | [FFFFFFFFF]

**\*44**

**Part. 1 Secondary Acct. No.**

| | | | / | | | | | [FFFFFFFFF]

**\*45**

**Partition 2 Primary Acct. No.**

| | | | / | | | | | [FFFFFFFFF]

**\*46**

**Partition 2 Secondary Acct. No.**

Enter 4 or 10 digits, as chosen in \*48 Report Format. Enter digits 0–9; #+11 for B; #+12 for C; #+13 for D; #+14 for E; #+15 for F.

| | | | / | | | | | [FFFFFFFFF]

Enter [\*] as the fourth digit if a 3-digit account number (for 3+1 dialer reporting format) is used. Enter 0 as the first digit of a 4-digit account no. for 0000-0999. E.g., For Acct. **B234**, enter: #+11 + 2 + 3 + 4

To clear entries in a given field, press \*43\*, \*44\*, \*45\*, or \*46\* based on the field being programmed

**\*47**

**Phone System Select**

If Cent. Sta. is not on a WATS line:  
0=Pulse Dial; 1=Tone Dial  
If Cent. Sta. is on a WATS line:  
2 = Pulse Dial; 3 = Tone Dial

[1]

Select the type of phone service for the installation.

**\*48**

**Report F ormat**

0 = 3+1, 4+1 ADEMCO L/S STANDARD  
1 = 3+1, 4+1 RADIONICS STANDARD;  
2 = 4+2 ADEMCO L/S STAND.  
3 = 4+2 RADIONICS STANDARD  
5 = 10-digit ADEMCO CONTACT ID® REPORTING  
6 = 4+2 ADEMCO EXPRESS  
7 = 4-digit ADEMCO CONTACT ID® REPORTING  
8 = 3+1, 4+1 ADEMCO L/S EXP.;  
9 = 3+1, 4+1 RADIONICS EXP

[77]

primary secondary

Select the format for primary/secondary phone numbers

**\*49**

**Split/Dual Reporting**

0 = Standard/backup reporting only (all to primary)  
1-5 = see table at right

[0]

**Backup Reporting:** All reports are sent only to the primary number unless unsuccessful after 8 attempts. If unsuccessful, the system will make up to 8 attempts to send all reports to the secondary number. If still unsuccessful after the 16 attempts, the system displays the "COMM. FAILURE" message (FC for fixed-word displays).

Primary Phone No.	2nd Phone No.
1 = Alarms, Restore, Cancel	Others
2 = All except Open/Close, Test	Open/Close, Test
3 = Alarms, Restore, Cancel	All
4 = All except Open/Close, Test	All
5 = All	All

**\*50**

**Burglary Dialer Delay**

**Delay Time:**

0 = no delay  
1 = 15 seconds  
2 = 30 seconds  
3 = 45 seconds

[2,0]

Delay Time **V20PSIA/V15PSIA**  
Delay Disable

Provides delay of "BURGLARY ALARM" report to the central station, which allows time for the subscriber to avoid a false alarm transmission. This delay does not apply to zone type 24 alarms (silent burglary) or to 24-hour zone types 6, 7, and 8 (silent panic, audible alarm, auxiliary alarm), which are always sent as soon as they occur.

UL: Delay Time must be 0

SIA Guidelines: delay must be minimum of 15 seconds

**V20PSIA/V15PSIA:**

**Delay Time:**

1 = 15 seconds  
2 = 30 seconds  
3 = 45 seconds

**Delay Disable:**

0 = use delay set in entry 1  
1 = dial delay disabled for zones listed in zone list 6 (use zone list 6 to enter those zones that require dial delay to be disabled; these zones ignore the setting in entry 1)

UL: Dial delay plus entry delay must not exceed one minute; use zone list 6 to disable dial delay from appropriate zones, if necessary.

**\*53**

**SESCOA/Radionics Select**

0 = Radionics (0-9, B-F)  
1 = SESCOA (0-9 only reporting)

[0]

Enter 0 for all non-SESCOA formats.

**\*54**

**Dynamic Signaling Delay**

0 = no delay (both signals sent)  
1 = 15 secs  
2 = 30 secs, etc.

[0]

Select delay from 0 to 225 secs, in 15-sec increments. Intended for reporting via a communication device on the ECP bus (LRR). This field lets you select the time the panel should wait for acknowledgment from the first reporting destination (see \*55) before it attempts to send a message to the second destination. Delays can be selected from 0 to 225 seconds, in 15-second increments. This delay is per message. If 0 is entered in this field, the control panel will send redundant reports to both Primary Dialer and communication device.

UL: If using line security, must be 0. Reports will be sent to both the dialer and the communication device.

**\*55**

**Dynamic Signaling Priority / AAV Path Select**

0 = Primary Dialer first / AAV via phone line  
1 = Communication Device (LRR) first / AAV via communication device path (see AAV Path Select paragraph at right)

[0]

This field selects the primary communication path for reporting (dialer or communication device) of **primary phone number** events† (see \*49 Split/Dual Reporting) **and** selects the communication path used for AAV sessions (phone line or communication device path). Use \*29 IP/GSM menu mode to enable the communication device being used.

† Dynamic signaling applies only to the primary phone number. Reports intended for the secondary phone number are not sent via the communication device.

For UL Commercial Burglary installations that use a DACT and LRR, this field must be 0.

**For Dynamic Signaling Priority:** Select the initial reporting destination for messages as follows:

**Primary Dialer First selected (0):**

- If acknowledged before delay expires (see \*54), then message will not be sent via LRR.
- If not acknowledged before delay expires, message is sent to both the Primary Phone No. and via LRR.

**Communication Device (LRR) First selected (1):**

- If acknowledged before delay expires, then message will not be sent to the primary dialer.
- If not acknowledged before delay expires, message is sent to both the Primary Phone No. and via LRR.



**For AAV Path Select:**

- If using the UVS system or AVS system with non-ECP connection, option 0 must always be used.
- If using the AVS system with ECP connection, either option (0 or 1) may be used, but note the following:  
**IMPORTANT:** If option “1” is selected, a 2-way voice (AAV) device compatible with the communication device path must be used (ex. GSMV4G, GSMX4G communicator). When selected, AAV sessions **always** occur via the GSM communicator, even if reporting reverts to phone line backup due to GSM communicator path reporting failure.

**\*56, \*57, \*58 Menu Modes**

These are Menu Mode commands, not data fields, for Zone Programming, Function Key Programming, and Expert Mode Zone Programming respectively. See page 3 and respective sections later in this document.

**TO PROGRAM SYSTEM STATUS, & RESTORE REPORT CODES (\*59 thru \*68, \*70 thru \*76, and \*89):**

**For 3+1 or 4+1 Standard Format:** Enter a code in the *first* box:

1–9, #+10 for 0, #+11 for B, #+12 for C, #+13 for D, #+14 for E, #+15 for F.

A 0 (*not* #+10) in the *first* box disables a report. A 0 (*not* #+10) in the *second* box results in advance to the next field.

**For Expanded or 4+2 Format:** Enter codes in *both* boxes (1st and 2nd digits) for 1–9, 0, or B–F, as described above.

A 0 (*not* #+10) in the *second* box will eliminate the expanded message for that report. A 0 (*not* #+10) in *both* boxes will disable the report.

**For Ademco Contact ID® Reporting:** Enter any digit (other than 0) in the *first* box, to enable zone to report (entries in the *second* boxes are ignored). A 0 (*not* #+10) in the *first* box disables the report.

UL: Report codes are required in fields \*61, \*65, \*71, \*72, for UL Commercial Burglar Alarm installations.

Report codes are required in fields \*60, \*62, \*63, \*64, \*70, \*73, \*74, \*75, \*76, for UL Commercial Burglar Alarm installations and required for Residential Fire Alarm installations

**SYSTEM STATUS REPORT CODES (\*59–\* 68)**

**\*59**

**Exit Error Alarm Report Code**

See above for entries.

[0]

After arming the system, entry/exit and interior zones remaining open after exit delay expires cause an alarm sound at the keypad and external sounder (keypad also displays “EXIT ALARM”), and entry delay begins. Disarming before the end of the entry delay stops the alarm sounding and no message is sent to the central station. Keypad displays “CA” (fixed-word) or “ALARM CANCELED” (alpha display). If the system is not disarmed before entry delay expires, an “EXIT ALARM” message (**V20PSIA/V15PSIA**; also zone alarm message) will be sent to the central station. The keypad will display “EA” (fixed-word) or “EXIT ALARM” (alpha display), and alarm sounding continues until the system is disarmed (or timeout occurs).

An Exit Alarm condition will also result if a fault occurs in an exit or interior zone within 2 minutes following the end of the exit delay, and an “EXIT ALARM” message will be sent to the central station (except for **V20PSIA/V15PSIA**, see field \*69 Recent Closing report). With Contact ID format, the message will contain the zone number and error code 374 (“ALARM–EXIT ERROR”).

**V20PSIA/V15PSIA:**  
[1] Always enabled.

**\*60**

**Trouble Report Code**

See above for entries.

[10] See UL System Reporting Note above \*59.

Sent if a zone has a trouble condition.

**\*61**

**Bypass Report Code**

See above for entries.

[00] See UL System Reporting Note above \*59.

Sent when a zone is manually bypassed.

**\*62**

**AC Loss Report Code**

See above for entries.

[10] See UL System Reporting Note above \*59.

Timing of this report is random with up to a 4-hour delay. If AC restores before the report goes out, there is no “AC LOSS” report.

**\*63**

**Low Bat Report Code**

See above for entries.

[10] See UL System Reporting Note above \*59.

Sent when the system’s backup battery has a low-battery condition.

**\*64**

**Test Report Code**

See above for entries.

**Periodic Test Report Schedule Commands:**

- every 24 hrs = installer code + [#] + [0] + 0
- once per week = installer code + [#] + [0] + 1
- every 28 days = installer code + [#] + [0] + 2

[00] See System Reporting UL Note above \*59.

Sent periodically to test the communicator and phone lines. Frequency of report is set in Scheduling mode (event 11) or by the key commands listed at left: Each mode sets schedule 32 (VISTA-20P) or schedule 08 (VISTA-15P) to the stated repeat option; first test report sent 12 hours after command.†

† **NOTE:** Make sure the Real-Time Clock is set to the proper time **before** entering the test report schedule command to ensure that test reports are sent when expected. (see Setting the Real-Time Clock section)

**\*65**

**Open Report Code**  
See above for entries.

[0,0,0] [System Reporting Note above \\*59.](#)  
Part. 1 Part. 2 Common  
Sent upon disarming the system in the selected partitions. [See UL](#)

**\*66**

**Arm Away/Stay Rpt Code**  
See above for entries.

[0,0,0,0,0,0]  
Away Stay Away Stay Away Stay  
Part. 1 Part. 2 Common  
This option allows for independent programming of Away and Stay reports for each partition, including the common lobby.  
**NOTE:** "OPEN" reports are not sent if the associated closing report is not enabled.

**\*67**

**RF Trans. Low Bat Report Code**  
See above for entries.

[00] [UL: must be enabled if wireless devices are used](#)  
Sent when a transmitter low-battery condition exists.

**\*68**

**Cancel Report Code**  
See above for entries.

[00]  
Sent upon disarming the system after an alarm condition was reported.

**V20PSIA/V15PSIA:** [10]  
Report enabled.

**\*69**

**Recent Closing Report Code**  
Not applicable to V15P/V20P  
See above for entries.

[11]

**V20PSIA/V15PSIA:**  
Always enabled.

**V20PSIA/V15PSIA:** Field does not apply to other controls.  
Similar to the Exit Error condition described in field \*59, but occurs if any burglary zone is faulted within two minutes **after** the initial exit delay expires. Disarming the system within the two minutes stops the alarm sound and displays "ALARM CANCELED" or "CA" and faulted zone number. No message is sent to the Central Monitoring Station. If the system is not disarmed within two minutes, the alarm sound continues and a "recent closing" and a "zone alarm" message are sent to the Central Monitoring Station (after dial delay expires).

**RESTORE REPORT CODES (\*70 – \*76)**

**\*70**

**Alarm Restore Rpt Code**  
See above for entries.

[0]  
Alarm restore signals indicate that respective alarm zone(s) are no longer faulted. Alarm restore reports are sent to the central station at bell timeout (field \*33), if the zone(s) in alarm are actually restored to a non-faulted state at that time. Otherwise, alarm restore report(s) for respective alarm zones are sent when the system is disarmed.  
[See UL System Reporting Note above \\*59.](#)  
If **Reports Per Armed Period Per Zone** (\*93) is also programmed, the system will report alarm and restore codes as described above until the "Reports Per Armed Period" count is reached. Disarming and rearming will reset the "Reports Per Armed Period" count.

**\*71**

**Trouble Restore Rpt Code**  
See above for entries

[00]  
Sent when a trouble in a zone is restored and code + OFF performed.  
[See UL System Reporting Note above \\*59.](#)

**\*72**

**Bypass Restore Rpt Code**  
See above for entries.

[00]  
Sent when a zone that has been bypassed is unbypassed.  
[See UL System Reporting Note above \\*59.](#)

**\*73**

**AC Restore Rpt Code**  
See above for entries.

[00] [See UL System Reporting Note above \\*59.](#)  
Sent after AC power has been restored after an AC power outage.

**\*74**

**Low Bat Restore Rpt Code**  
See above for entries.

[00] [See UL System Reporting Note above \\*59.](#)  
Sent after a system low-battery condition is restored to normal.

**\*75**

**RF Trans. Lo Bat Rst Rpt Code**  
See above for entries.

[00]  
Sent when a transmitter's low battery condition is restored (i.e., new battery installed).  
[UL: must be enabled if wireless devices are used. See UL System Reporting Note above \\*59.](#)

**\*76**

**Test Restore Rpt Code**  
See above for entries.

[00] [See UL System Reporting Note above \\*59.](#)  
This is sent when the Test mode is exited or upon timeout (4hrs).

## OUTPUT AND SYSTEM SETUP (\*77 – \*93)

**\*77**

### Daylight Saving Time Start/End Month

0 = Disabled  
 1-9 = Jan.-Sept. (1 = Jan, 2 = Feb, etc)  
 #+10 = October  
 #+11 = November  
 #+12 = December

[3][11]

Enter the start and end month for daylight saving time, if applicable to the region.

**\*78**

### Daylight Saving Time Start/End Weekend

0 = disabled      4 = fourth  
 1 = first          5 = last  
 2 = second       6 = next to last  
 3 = third          7 = third to last

[2][1]

Enter the start and end weekend for daylight saving time, if applicable to the region.

**\*79, \*80, \*81, \*82 Menu Modes**

These are Menu Mode commands, not data fields, for Output Device Mapping, Output Programming, Zone List Programming, and Alpha Programming respectively. See page 3 and their respective sections for procedures.

**\*84**

### Auto Stay Arm

0 = no  
 1 = partition 1 only  
 2 = partition 2 only  
 3 = both partitions

[3]

If enabled, the system will automatically change AWAY mode to STAY mode if the entry/exit door **is not** opened and closed within the exit delay time after a user arms in AWAY mode from a wired keypad (non-RF device). An Opening report followed by an Armed Stay report is sent to the Central Station.

If the door **is** opened and closed within the exit delay period, the system remains in AWAY mode.

Any RF device that arms the system AWAY overrides this feature and the system remains armed AWAY.

**\*85**

### Cross Zone Timer

0 = 15 secs    6 = 2-1/2 min    #+12 = 8 min  
 1 = 30 secs    7 = 3 min        #+13 = 10 min  
 2 = 45 secs    8 = 4 min        #+14 = 12 min  
 3 = 60 secs    9 = 5 min        #+15 = 15 min  
 4 = 90 secs    #+10 = 6 min  
 5 = 2 min        #+11 = 7 min

[0] This option not for use in UL installations.

Sets the maximum amount of time in which two cross zones must be tripped in an armed system to send an alarm message to the Central Station. If only one cross zone is tripped during this time, a trouble message (CID code 380) for that zone is sent to the Central Station. Assign cross zones on zone list 4, using \*81 Menu mode.

**NOTE:** Cross zoning takes effect only after Exit Delay expires.

**\*86**

### Cancel Verify Keypad Display

0 = no "alarm canceled" display  
 1 = display "Alarm Canceled" when system is disarmed after an alarm has occurred. (To clear the "ALARM CANCELED" display, the user must enter the security code + OFF again.)

[1]

This feature causes a "**ALARM CANCELED**" display on the LCD keypad under the following conditions:

- After the kissoff of the cancel message to the Central Station, indicating a successful transmission.
- When an alarm is successfully canceled before the Central Station received the Alarm message. E.g., if an alarm is incorrectly triggered and the user presses code + OFF before the dial delay time has expired, the message will never go out to the CS.
- When the Cancel report is not enabled and the system is disarmed:
  - a. **before** dialer delay expires (alarm report not sent) message "Alarm Canceled" is displayed.
  - b. **after** dialer delay expires message "Alarm Canceled" is not displayed.

**NOTE:** Applies only when the Dialer is selected as the primary communication path (\*55 = 0).

**\*87**

### Misc. Fault Delay Time

0 = 15 secs    6 = 2-1/2 min    #+12 = 8 min  
 1 = 30 sec     7 = 3 min        #+13 = 10 min  
 2 = 45 secs    8 = 4 min        #+14 = 12 min  
 3 = 60 secs    9 = 5 min        #+15 = 15 min  
 4 = 90 secs    #+10 = 6 min  
 5 = 2 min        #+11 = 7 min

[0]

(used with Configurable Zone Types "digit 6")

Used with zones assigned to a configurable zone type with fault delay on (configurable zone type digit "6"), and sets a zone response time of 15 seconds to 15 min. It can be assigned to zones with sensors that provide a trouble indication when an oil tank is low, or similar applications for critical condition monitoring where a non-alarm response is desired.

UL: may only be used on non-burglar alarm/ non-fire alarm zones when used in fire and/or UL burglar alarm installation

**\*88**

### Program Mode Lockout Options

0 = standard \*98 installer code lockout (reentry only by [\*] + [#] within 50 secs after power up)  
 1 = lockout [\*] + [#] reentry after \*98 exit (reenter via installer code or downloader only)  
 2 = lockout local programming after \*98 exit (reenter by downloader only)

[0] This table summarizes the Program Mode Lockout options:

Exit Command	*88 Entry	Reentry By: Installer	Power-up†	Downloader
*99	n/a	yes	yes	yes
*98	0	no	yes	yes
*98	1	yes	no	yes
*98	2	no	no	yes

† pressing [\*] + [#] within 50 seconds of power up

**\*89**

**Event Log Full Report Code**

See box above field \*59 for report code entries.

[00]

If an Event Logging selection is made in field \*90, a message can be sent to the central station receiver when the log is 80% full. If the log becomes full, new messages overwrite the oldest messages in the log.

**\*90**

**Event Log Enables**

- 0 = None
- 1 = Alarm/Alarm Restore
- 2 = Trouble/Trouble Restore
- 4 = Bypass/Bypass Restore
- 8 = Open/Close.

*Example:* To select "Alarm/Alarm Restore", and "Open/Close", enter 9 (1 + 8)  
To select all, enter #15.

[3]

This system can record various events in a history log (VISTA-20P = 100 events; VISTA-15P = 50 events). At any time, the downloader operator can then upload the log and view or print out all or selected categories of the log, or can clear the log. Event log can also be viewed at an alpha keypad. The display/printout at the central station will show the date, time, event, and description of the occurrences.

Data Entry Example: To select Alarm/Alarm Restore" and "Open/Close", enter 9 (1+ 8); to select all events, enter #15.

**NOTE:** System messages are logged when any non-zero entry is made.

**\*91**

**Option Selection / Remote Interactive Services (RIS) Enable**  
**Entry 1: Options**

- 0 = None
- 1 = Bell Supervision Processing
- 4 = AAV
- 8 = Exit Delay Restart/Reset†
- #+12 = AAV and Exit Delay Restart/Reset

**Entry 2: Remote Interactive Services (RIS) enable**

- 0 = RIS disabled
- 1 = not applicable
- 2 = RIS enabled

[8, 0]

Options RIS Enable  
**V20PSIA/V15PSIA: Call Waiting Disable / RIS Enable**

**IMPORTANT:** AAV should not be used when Paging or Alarm Reports are sent to a secondary number unless the monitoring zone option is used (which pauses calls). Otherwise, the call to the secondary number by the communicator after the alarm report will prevent the AAV from taking control of the telephone line, and the AAV "Listen in" session cannot take place.

UL: for AAV, must use Honeywell AVS system; Exit Delay Restart/Reset must be disabled

SIA Guidelines: Exit Delay Restart/Reset should be enabled.

† "Exit Delay Restart/Reset" option allows use of the [\*] key to restart the exit delay at any time when the system is armed STAY or INSTANT. This feature also enables automatic exit delay reset, which resets exit delay if the entry/exit door is re-opened and closed before exit delay time expires after arming AWAY. Automatic Exit Delay Reset occurs only once during an armed AWAY period.

**Remote Interactive Services (RIS) Enable:** This option enables enhanced Remote Interactive Services (RIS) such as Total Connect 2.0, Tuxedo/Z-Wave scenes and Home Automation (Control 4, 4232CBM), if supported by the communication service in use. If enabled, device address 25 is automatically assigned.

**To Enable Remote Services:**

1. Enable the RIS option in this programming field (entry 2).
2. Use field \*189 to enable a remote services emulated keypad address.
3. Use \*29 Menu mode to enable the communication device.
4. If using Total Connect 2.0, use AlarmNet Direct website to program the communicator and enable TC2 services. Be sure to "send" the programming data down to the Communicator.

**V20PSIA/V15PSIA:**  
**Entry 1 Options:** Same as above.  
**Entry 2 Call Waiting Disable / RIS Enable:**  
 0 = call waiting not used  
 1 = use call waiting disable digits (\*70) entered in field \*40; (when selected, the system dials the entry in \*40 only on alternate dial attempts; this allows proper dialing in case call waiting service is later canceled by the user).  
 2 = RIS (Remote Interactive Services) enabled  
 3 = Call Waiting disable and RIS enabled

**\*92**

**Phone Line Monitor Enable**

**Entry 1::**

- 0 = disabled, 1-15 = 1 min - 15 min (#+10 = 10 min; #+11 = 11 min; #+12 = 12 min; #+13 = 13 min; #+14 = 14 min; #+15 = 15 min)

**Entry 2:**

- 0 = Keypad display when line is faulted
- 1 = Keypad display plus keypad trouble sound. Each partition turns off its own trouble sound. No automatic timeout.
- 2 = Same as "1", plus programmed output device STARTS. If either partition is armed, external sounder activates also. External sounder will be turned off by normal bell timeout, or by security code plus OFF from either partition (it need not be the one that was armed).

[0,0]

1 2

**Entry 1:** Sets the length of time a phone line fault must remain after detected before the second digit option is activated.

**Entry 2:** Selects the desired phone line fault response.

Option 2 may be used even if a relay unit or Powerline carrier device is not connected to the control.

Programmed Output Device must either be programmed to be STOPPED in field \*80 or STOPPED by entry of [security code] + [#] + 8 + device number. Partition in \*80 should be set to "0," for STOP.

UL: Field \*92 must be enabled for fire alarm installations, UL commercial burglar alarm installations and UL residential burglar alarm installations.

If the control unit is used on a UL commercial burglar alarm system which requires 2 methods of remote communication, then the control unit's DACT and the other method of signal transmission must monitor each other against communication failure and line fault. The fault must be received and annunciated within 200 seconds of its occurrence.

**\*93**

**Reports In Armed Period Per Zone** (Swinger Suppression)

**Restrict Report Pairs:**

- 0 = Unlimited Reports
- 1 = 1 report pair per zone per armed period
- 2 = 2 report pairs per zone per armed period

 [1,0]

Restrict Report Pairs **V20PSIA/V15PSIA** Unlimited Reports Enable

Selection limits the number of alarm/alarm restore message pairs per zone sent to the CS in an armed period. Swinger suppression applies to burglary zones only.

SIA Guidelines: Must be set for option 1 or 2

**V20PSIA/V15PSIA:**  
**Restrict Report Pairs:**  
 1 = 1 report pair; 2 = 2 report pairs  
**Unlimited Reports Enable:**  
 0 = restrict reports to the setting in entry 1  
 1 = unlimited reports for zones listed in zone list 7; (use zone list 7 to enter those zones that require unlimited reporting; these zones ignore the setting in entry 1)

**DOWNLOAD INFORMATION (\*94, \*95)**

**\*94**

**Download Phone No.**

Enter up to 20 digits, 0-9; #+11 for '\*'; #+12 for '#'; #+13 for a 2-second pause. Do not fill unused spaces. If fewer than 20 digits, exit field by pressing \*. To clear entries from field, press \*94\*.

Enter the phone number of the downloading computer.

UL: downloading may be performed only if a technician is at the site. Up/downloading via the Internet has not been evaluated by UL.

**\*95**

**Ring Count For Downloading**

- 0 = Disable Station Initiated Download;
- 1-14 = number of rings (1-9, # +10 =10, # +11 =11, # +12 =12, # +13 =13, # +14 =14);
- 15 = answering machine defeat (# +15 =15).

**NOTE:** Do not enter 0 if using 4286 Phone Module.

 [15]

Refer to the chart below and program accordingly.

phone module	answer machine	down-loading	Set field *95 to...
yes	no	no	1-14 (not 0)
yes	yes	no	greater than rings set on answer machine (e.g., if ans. machine is 4 rings, set this field to 5). This allows access to the phone module if the answer machine is off.
yes	no	yes	1-14 (not 0)
yes	yes	yes	15 (bypasses answer machine†)
no	no	no	0
no	yes	no	0
no	no	yes	1-14
no	yes	yes	15

† **NOTE:** If "15" is entered to bypass an answering machine, and a 4286 Phone Module is included in the system, you should note the following: When calling in from an off-premises phone, the user should make the initial call, allow 1 or 2 rings only, then hang up, then call again. The phone module will now seize the line, and 2 long tones sound, followed by the usual voice prompt for the access code. If this procedure is not followed, phone module operation will not be possible.

**\*96**

**\*97**

**Initialize/Reset Defaults** (These are commands, not data fields. See page 3.)

**\*98**

**\*99**

**Exit Commands** (These are commands, not data fields. See page 3.)

**PAGER OPTIONS (\*160- \*172)**

The system can send various reports to several pagers (VISTA-20P = up to 4; VISTA-15P = up to 2).

To program pager reporting, do the following:

1. Enter the pager phone number(s), preface characters, and pager report options in data fields \*160 - \*171.
2. Enable Pager Delay, if desired, in field \*172 (delays alarm reporting for ALL pagers).
3. Make sure appropriate user open/close pager reports are enabled (see Security Codes section in User Guide). Users that perform actions in partition 1 will, if enabled, attempt to report to all pagers enabled for open/close reporting in partition 1. Users that perform actions in partition 2 will, if enabled, attempt to report to all pagers enabled for open/close reporting in partition 2.
4. If using latchkey pager report, define the latchkey report schedule using Scheduling mode (master code + [#] [6] [4] then select event type 03). System must be armed for the Latchkey report to be sent.
5. If using a function key to manually send a message to a pager, use \*57 Function Key Menu mode to define the key (function 01).
6. If reporting zone alarms and troubles to a pager, use \*81 Zone List menu mode to assign the zones associated with each pager (zone lists 9-12†).

† VISTA-15P supports zone lists 9 and 10 only.

**\*160**

**Pager 1 Phone No.**

Enter up to 20 digits. 0-9

#+11 = '\*'

#+12 = '#'

#+13 = 2-second pause

\_\_\_\_\_

If entering fewer than 20 digits, exit by pressing [\*] + next field number. To clear entries, press \*160\*.

**\*161**

**Pager 1 Characters**

Enter the optional prefix characters, up to 16 digits.

0-9

#+11 = '\*'

#+12 = '#'

#+13 = 2-second pause

\_\_\_\_\_

Up to 16 optional characters may be sent as a prefix to the 7-digit system status code sent to Pager #1 (if used). Phone number in field \*160 must have been entered. If fewer than 16 characters, exit by pressing [\*] and next field number. To clear entries: press \*161\*.

The 16 characters may be composed of the following:

PIN number, Subscriber account number,

\* character, # character, 2-second pause,†

special character(s) the user may decide to transmit

† Some paging systems require pause(s) before the prefix.

The Pager format for the 7-digit status code is defined as follows: XXX-YYYY where:

XXX = 3-digit event code: 911 = Alarm, 811 = Trouble, 101 = Opening (disarm), 102 = Closing (arm AWAY)

YYYY = 4-digit user or zone number (depending on type of event).

The first digit indicates partition (0 = system, 1 = part 1, 2 = part 2, 3 = common), followed by the 3-digit user or zone number.

Display Example 1. 9 1 1 - 1 0 0 4

Indicates an alarm (911) caused by a fault in zone 4 (0004) in part. 1.

Display Example 2. 1 0 2 - 2 0 0 5

Indicates the system is reporting a closing-system arming (102) by User 5 (0005) in partition 2.

**\*162**

**Pager 1 Report Options**

0 = no reports sent

1 = Opens/closes all users†

4 = All alarms and troubles

5 = All alarms / troubles, and opens/closes for all users

12 = Alarms / troubles for zones entered in zone list 9

13 = Alarms / troubles for zones entered in zone list 9, and opens/closes for all users

[0,0,0]

P1 P2 comm

For each partition, select from the listed options.

† For users enabled for paging. Reports to pager only when arming (close)/disarming (open) from a keypad using a security code; auto-arming/disarming, arming with assigned button, and keyswitch arming do not send pager messages.

**\*163**

**Pager 2 Phone No.**

See field \*160 for entries.

\_\_\_\_\_

If entering fewer than 20 digits, exit by pressing [\*] + next field number. To clear entries, press \*163\*.

**\*164**

**Pager 2 Characters**

See field \*161 for entries.

\_\_\_\_\_

If fewer than 16 characters, exit by pressing [\*] and next field number. To clear entries, press \*164\*.

**\*165**

**Pager 2 Report Options**

See field \*162 for reporting options.

[0,0,0]

P1 P2 comm

Select for each partition (use zone list 10 for options 12 or 13)

**\*166**

**Pager 3 Phone No.**

See field \*160 for entries.

\_\_\_\_\_

If entering fewer than 20 digits, exit by pressing [\*] + next field number. To clear entries, press \*166\*.

**\*167**

**Pager 3 Characters**

See field \*161 for entries.

\_\_\_\_\_

If fewer than 16 characters, exit by pressing [\*] and next field number. To clear entries, press \*167\*.

**\*168**

**Pager 3 Report Options**

See field \*162 for reporting options.

[0,0,0]

P1 P2 comm

Select for each partition (use zone list 11 for options 12 or 13).

**\*169**

**Pager 4 Phone No.**

See field \*160 for entries.

\_\_\_\_\_

If entering fewer than 20 digits, exit by pressing [\*] + next field number. To clear entries, press \*169\*.

**\*170**

**Pager 4 Characters**

See field \*161 for entries.

\_\_\_\_\_

If fewer than 16 characters, exit by pressing [\*] and next field number. To clear entries, press \*170\*.

**\*171**

**Pager 4 Report Options**

See field \*162 for reporting options.

[0,0,0]

P1 P2 comm

Select for each partition (use zone list 12 for options 12 or 13).

**\*172 Pager Delay Option For Alarms**

- 0 = none
- 1 = 1 minute
- 2 = 2 minutes
- 3 = 3 minutes

 [3]

This field determines the delay of alarm reports to the pager. This gives the Central Station enough time to verify the alarm report it received before the dialer attempts to dial the pager.  
This delay is for ALL pagers in the system.

**MISCELLANEOUS SYSTEM FIELDS (\*174-\*181)****\*174 Clean Me Reporting Options**

- 0 = disable
- 1 = Clean Me signal reports

 [0]

For ESL smoke detectors  
This is a maintenance feature for ESL 2-wire smoke detectors on Zone 1. If used, this option limits the number of smoke detectors to a maximum of 10, rather than 16. To enable the "clean me" feature, a time response setting of "3" (1.2 seconds) must be entered in \*56 Zone Programming for zone 1.  
**NOTE:** If Clean Me is enabled, you must enter "3" in field \*56 programming for zone 1 response time.

**\*177 Device Duration 1, 2**

- 0 = 15 secs    6 = 2-1/2 min    #+11 = 7 min
- 1 = 30 secs    7 = 3 min    #+12 = 8 min
- 2 = 45 secs    8 = 4 min    #+13 = 10 min
- 3 = 60 secs    9 = 5 min    #+14 = 12 min
- 4 = 90 secs    #+10 = 6 min    #+15 = 15 min
- 5 = 2 min

  [0] [0]

1                      2  
(used in \*80 Menu mode-Device Actions 5/6)  
These entries set the duration for output action options 5 (duration 1) and 6 (duration 2) programmed in \*80 Output Function Programming.

**\*181 50/60 Hertz AC Operation**

- 0 = 60 Hz; 1 = 50 Hz

 [0]

Select the type of AC power applied to the control (option is used for Real-Time Clock synchronization)

**CONFIGURABLE ZONE TYPE OPTIONS (\*182-\*185)**

(see Configurable Zone Type Worksheet following data field \*199)

- The system allows you to define custom zone types (VISTA-20P supports 4 [types 90-93]; VISTA-15P supports 2 [types 90, 91]) based on the options selected.
- All configurable zone types can be programmed via the downloader. Zone types 90-91 can also be programmed from a keypad using data fields \*182-\*185.
- **IMPORTANT:** Be careful when selecting combinations of options for configurable zone types. Contradictory options can cause unpredictable results.

**Configurable Zone Type Options**

<b>Auto Restore</b> (entry 2): Faults on zones set for this option are cleared; restore messages sent upon restoral of faults.
<b>Vent Zone</b> (entry 2): Zones set for this option are ignored if faulted when arming the system, but are protected if the zone is later restored (e.g., an open window can be ignored when arming, but if the window is later closed, it will be protected; opening the window again causes an alarm.)
<b>Bypass Disarmed</b> (entry 4): Zones set for this option can be bypassed only while the system is disarmed.
<b>Bypass Armed</b> (entry 4): Zones set for this option can be bypassed when the system is armed.
<b>Dial Delay</b> (entry 6): Alarms on zones set for this option participate in dial delay central station reporting, if system dial delay enabled in field *50.
<b>Fault Delay</b> (entry 6): Faults on zones set for this option are delayed by the time set in field *87. Do not use this option if using entry/exit delay for this zone type.
<b>Faults Display</b> (entry 7): Selects how faults on zones set for this zone type are displayed.
<b>Power Reset/Verification</b> (entry 7): Selects whether the system resets power (when user enters code + OFF), and whether the system performs alarm verification (see description for zone type 16 in <b>Zone Type Definitions</b> section) when a fault occurs on these zones.
<b>Use Entry Delay</b> (entry 8): Selects whether to use the system's entry delay times.
<b>Use Exit Delay</b> (entry 8): Selects whether to use the system's exit delay time.
<b>Interior Type</b> (entry 8): Zones set for this option are treated same as standard zone type 4 (bypasses when armed STAY, faults displayed).
<b>Alarm Sounds</b> (entry 9): Selects the type of alarms sound for zones set for this zone type.
<b>Bell Timeout</b> (entry 9): Alarm sounding on zones set for this option remain for the duration set in fields *32 / *33.
<b>Fire Zone</b> (entry 9): Zones set for this option respond in the same manner as if programmed for zone type 9. Do not set fire zones to respond as a "fault" in entries 1-6.
<b>Trouble Sounds</b> (entry 10): Selects the type of trouble sounds for zones set for this zone type (periodic beeps = once every 30 seconds; trouble beeps = rapid beeping).
<b>Chime Enable</b> (entry 10): Zones set for this option cause a chime when Chime mode is on.

**\*182****Configurable Zone Type 90**

(0-9, #+10=10, #+11=11, #+12=12, #+13=13, #+14=14, #+15=15).

<input type="checkbox"/>	<input type="checkbox"/>	<input type="checkbox"/>	<input type="checkbox"/>	<input type="checkbox"/>	<input type="checkbox"/>	<input type="checkbox"/>	<input type="checkbox"/>	<input type="checkbox"/>	<input type="checkbox"/>
1	2	3	4	5	6	7	8	9	10

Enter the appropriate value for each entry, 1-10, based on the charts provided in the Configurable Zone Type Worksheet section. Each entry is the sum of the values of its selected options

To calculate the value for each entry, add the values of the selected options in each of the entry's columns shown in the respective chart (one option per column). For example, to program entry 2 for "alarm response to short," "auto restore on," but not a "vent zone," enter 5 ("1" for alarm short + "4" for auto restore-yes + "0" for vent zone-no).

UL: Do not configure zones as a fire alarm or UL burglar alarm zone.

**\*183****Zone Type 90 Report Codes**

90 ALARM ID: XXX
TROUBLE ID: XXX

Press [\*] when done to continue.

**NOTE:** Zone alarm report codes and trouble report code (\*60) and relevant restore codes must be enabled in order to report configurable zone type codes.

Enter the desired 3-digit Contact ID® report codes for alarms and troubles occurring on zones assigned to this zone type. Enter the codes sequentially (all 6 digits). When entering digits, [#] moves cursor back, [\*] moves forward.

**Important Notice on Report Codes:** To avoid confusion at the central station, it is recommended that existing Contact ID® codes be used with configurable zone types whenever possible. Check with the central station for a complete list of Contact ID® report codes. If none of the codes are suitable, choose a code in the reserved range of 750-789 and make sure to define the code with your central station.

**\*184****Configurable Zone Type 91**

(0-9, #+10=10, #+11=11, #+12=12, #+13=13, #+14=14, #+15=15).

<input type="checkbox"/>	<input type="checkbox"/>	<input type="checkbox"/>	<input type="checkbox"/>	<input type="checkbox"/>	<input type="checkbox"/>	<input type="checkbox"/>	<input type="checkbox"/>	<input type="checkbox"/>	<input type="checkbox"/>
1	2	3	4	5	6	7	8	9	10

See \*182 for entries.

UL: Do not configure zones as a fire alarm or UL burglar alarm zone.

**\*185****Zone Type 91 Report Codes**

91 ALARM ID: XXX
TROUBLE ID: XXX

See \*183 for entries.

**\*189****AUI Device Enables  
(for TouchScreen Style Keypads)****VISTA-20P:**

For Touchscreen device usage

- 0 = disable
- 1 = partition 1
- 2 = partition 2
- 3 = partition 3 (common)

For Remote Services device usage

- 5 = part. 1 (auto-stay arm disabled)
- 6 = part. 2 (auto-stay arm disabled)
- 7 = part. 3 (common; auto-stay arm disabled)

**VISTA-15P:**

For Touchscreen device usage

- 0 = disable
- 1 = enable

For Remote Services device usage

- 5 = part. 1 (auto-stay arm disabled)

**Device Addresses:**

Touchscreen device 1: Must set to 1  
 Touchscreen device 2: Must set to 2  
 Touchscreen device 3: Must set to 5  
 Touchscreen device 4: Must set to 6

<input type="checkbox"/>	<input type="checkbox"/>	<input type="checkbox"/>	<input type="checkbox"/>	[1, 1, 0, 0]
AUI 1	AUI 2	AUI 3	AUI 4	

System supports touchscreen style keypads (e.g., 6280, Tuxedo Touch; V20P = up to 4; V15P = up to 2).

**NOTE:** Use of touchscreen style keypads does not affect the number of standard keypads supported.

To enable a touchscreen keypad, enter the option corresponding to each touchscreen's home partition.

**Note for Remote Services Devices:** If using the Remote Services feature of the communication device, select an option 5-7, depending on the partition the Remote Services device is associated with (these options automatically disable auto-stay arming when the system is armed from the respective Remote Services device). Refer to the communication device's installation instructions for details on enabling the Remote Services feature.

**Note for Remote Services Device Address:** Using an AUI device address for Remote Services provides enhanced remote services features, but an actual AUI device cannot use the same address. If no AUI addresses are available (all four AUIs are being used), Total Connect 2 cannot be used for remote services. However, Total Connect 1 can be used by choosing an available standard keypad address and using the appropriate keypad address field \*190 - \*196 to select the Remote Services operating partition (some remote access features will be unavailable).

**KEYPAD OPTIONS \*190-\*196****To enable keypads:**

1. Set desired address at keypad (refer to keypad's instructions for setting the address).
2. Use data fields \*190-\*196 to enable keypad addresses, assign a partition, and enable sound options.
3. Use fields \*197, \*198, and \*199 to turn on partition number display, exit time interval display, and select fail display mode.
4. Set keypad-related data fields as appropriate: \*21 Quick Arm Enable, \*23 Forced Bypass, \*84 Auto STAY Arm

**NOTES:** 1. Options for keypad 1, address 16, are set by the factory and cannot be changed.

2. Each keypad must be assigned a unique address. Keypads programmed with the same address will give unpredictable results.



**\*190**

**Keypad 2 Device Address 17**

**Entry 1: Partition/ Enable**

**VISTA-20P:** Enter partition in which the keypad is located where:

- For Standard keypad usage
- 0 = disable
- 1 = partition 1
- 2 = part. 2
- 3 = part. 3 (common)

- For Remote Services device usage
- 5 = part. 1 (auto-stay arm disabled)
- 6 = part. 2 (auto-stay arm disabled)
- 7 = part. 3 (common; auto-stay arm disabled)

**VISTA-15P:**

- For Standard keypad usage
- 0 = disable
- 1 = enable

- For Remote Services device usage
- 5 = auto-stay arm disabled

**Entry 2: Sound**

- 0 = no suppression
- 1 = suppress arm/disarm and Entry/Exit beeps
- 2 = suppress chime beeps only
- 3 = suppress arm/disarm, Entry/Exit, and chime beeps

Partition/  
Enable

Sound

[0] [0]

**Entry 1 - Partition/Enable:** Enter the desired option for the keypad's home partition.

**Note for Remote Services Devices:** If using the Remote Services feature of the communication device, select an option 5-7 (option 5 for VISTA-15P), depending on the partition the Remote Services device is associated with (these options automatically disable auto-stay arming when the system is armed from the respective Remote Services device). Refer to the communication device's installation instructions for details on enabling the Remote Services feature.

**Entry 2 - Sound:** Enter the desired sound option for this keypad.

**\*191**

**Keypad 3 Device Address 18**

See field \*190 for entries.

Part./ Enable

Sound

[0] [0]

**\*192**

**Keypad 4 Device Address 19**

See field \*190 for entries.

Part./ Enable

Sound

[0] [0]

**\*193**

**Keypad 5 Device Address 20**

See field \*190 for entries.

Part./ Enable

Sound

[0] [0]

**\*194**

**Keypad 6 Device Address 21**

See field \*190 for entries.

Part./ Enable

Sound

[0] [0]

**\*195**

**Keypad 7 Device Address 22**

See field \*190 for entries.

Part./ Enable

Sound

[0] [0]

**\*196**

**Keypad 8 Device Address 23**

See field \*190 for entries.

Part./ Enable

Sound

[0] [0]

**\*197**

**Exit Time Display Interval**

- 0 = no display
- 1-5 = seconds between display refresh

[0]

**TOUCH SCREEN DEVICE NOTE:** If using more than one touch screen device (e.g., 6280, Tuxedo Touch) with the system, leave field \*197 Exit Time Display Interval set to the default value "0." The 6280 automatically displays remaining exit time in one-second increments.

If enabled, keypads display the exit time remaining after arming the system, updated at the interval selected (i.e. if the exit delay is 30 seconds and "2" is selected in this field, the keypad display refreshes every 2 seconds, displaying 30, 28, 26, 24, etc.).

An interval greater than "1" may be necessary for some older keypads to allow users time to enter key presses between display updates.

**NOTE:** If enabled and using only 2-digit fixed-word keypads (e.g., 6150RF), do not set exit delay time greater than 96 seconds. Using a longer delay time may cause end-user confusion because 2-digit display keypads cannot display times greater than "99." If longer exit time is required by the installation, it is recommended that the Exit Time Display option be disabled ("0").

**\*198**

**Display Partition Number**

- 0 = no
- 1 = yes (part. no. appears on display)

[0] (VISTA-20P; for Alpha Display Keypads)

If selected, the partition number is displayed in the upper-left corner of the alpha display. This is useful when using the GOTO partition function.

**\*199**

**ECP Fail Display**

- 0 = 3-digit display  
"1" + device address)
- 1 = 2-digit fixed-display as "91"

[0]

Select "0" if using Alpha keypads and/or 3-digit Fixed-Word Display keypads. ECP faults will display "1" plus the device address (00-15) of device causing the fault (e.g., faults on device 07 display as "107"). Select "1" if using 2-digit Fixed-Word Display keypads (e.g., certain 6128 series keypads). If selected, ECP faults for all devices will display as "91" on 2-digit displays, and "191" on 3-digit or Alpha keypads.

# CONFIGURABLE ZONE TYPES WORKSHEET

Configurable zone types 90 and 91 can be programmed via downloader software or from a keypad using data fields \*182- \*185. Configurable zone types 92 and 93 (VISTA-20P only) can only be programmed using the downloader software.

Programming Configurable Zone Type options involves making 10 entries in data field \*182 for zone type 90 and field \*184 for zone type 91, where each entry represents the sum of the values of the various options shown in the tables below. Use fields \*183 and \*185 to program Contact ID report codes for these zone types.

ENTRY 1 (See note 5 for RF zones)		ENTRY 2 (See note 5 for RF zones)		
Response when system disarmed		and zone is:		Auto Restore
Intact EOL <i>RF zone normal</i>	Open <i>RF zone N/A</i>	Shorted <i>RF zn off-normal</i>		Vent Zone
0 = normal 1 = alarm 2 = trouble 3 = fault	0 = normal 4 = alarm 8 = trouble 12 = fault	0 = normal 1 = alarm 2 = trouble 3 = fault see note 6	0 = no 4 = yes	0 = no 8 = yes
Entry 1 = EOL + Open		Entry 2 = Short + auto restore + vent zone		

ENTRY 3 (See note 5 for RF zones)		ENTRY 4 (See note 5 for RF zones)		
Response when armed STAY		and zone is:		Byp. when disarmed
Intact EOL <i>RF zone normal</i>	Open <i>RF zone N/A</i>	Shorted <i>RF zn off-normal</i>		Byp. when armed
0 = normal 1 = alarm 2 = trouble 3 = fault	0 = normal 4 = alarm 8 = trouble 12 = fault	0 = normal 1 = alarm 2 = trouble 3 = fault see note 6	0 = no 4 = yes	0 = no 8 = yes
Entry 3 = EOL + Open		Entry 4 = Short + byp. disarmed + byp. armed		

ENTRY 5 (See note 5 for RF zones)		ENTRY 6 (See note 5 for RF zones)		
Response when armed AWAY		and zone is:		Dial Delay (see field *50)
Intact EOL <i>RF zone normal</i>	Open <i>RF zone N/A</i>	Shorted <i>RF zn off-normal</i>		Fault Delay (see field *87)
0 = normal 1 = alarm 2 = trouble 3 = fault	0 = normal 4 = alarm 8 = trouble 12 = fault	0 = normal 1 = alarm 2 = trouble 3 = fault see note 6	0 = no 4 = use delay	0 = no 8 = use delay see note 1
Entry 5 = EOL + Open		Entry 6 = Short + dial delay + fault delay		

ENTRY 7		ENTRY 8		
Display Faults	Power Reset/ Verification	Use Entry Delay 1/2	Use Exit Delay	Respond as Interior Type
0 = show alarms when armed & disarmed 1 = don't show alarms when armed (show alarms, trbles, faults when disarmed) 3 = never show any alarms, trbles, faults	0 = no 4 = power reset after fault (by code + OFF) 12 = verification (see zone type 16)	0 = no 1 = delay 1 2 = delay 2	0 = no 4 = use exit delay	0 = no 8 = yes see note 2
Entry 7 = fault display + power reset/verification		Entry 8 = entry delay 1/entry delay 2 + exit delay + interior zone type		

ENTRY 9		ENTRY 10		
Alarm Sounds	Use Bell Timeout	Respond as Fire Zone	Trouble Sounds	Chime when Chime Mode On
0 = none 1 = steady keypad 2 = steady bell and keypad 3 = pulsing bell and keypad	0 = no 4 = yes see fields *32, *33	0 = no 8 = yes see zone type 09; see note 4	0 = none 1 = periodic beep 2 = trouble beeps	0 = no 4 = yes
Entry 9 = alarm sounds + bell timeout + fire zone		Entry 10 = trouble sounds + chime		

Entries for Fields *182 and *184		
Entry	Zone Type 90 (field *182)	Zone Type 91 (field *184)
1		
2		
3		
4		
5		
6		
7		
8		
9		
10		

**To calculate the value for each entry:**  
Simply add the values of the selected options in each of the entry's columns (one option per column). For example, to program Entry 2 for "alarm response to short," "auto restore on," but not a "vent zone," enter 5 ("1" for alarm short + "4" for auto restore yes + "0" for vent zone no).

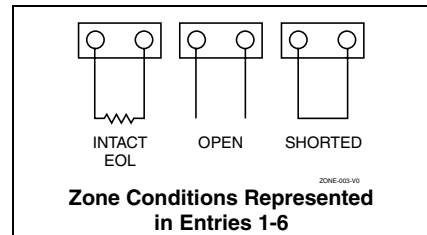

**NOTES:**

- Do not use the "fault delay" option with a configurable zone type if it is set for an entry or exit delay, otherwise unpredictable results may occur.
- To create an interior type zone, select "respond as interior zone type" (entry 8, interior type = yes), and set zone response to "fault" in entries 3-4 to ensure fault displays; do not set as "normal," "alarm," or "trouble."
- Do not set fire zones to respond as a "fault" (entries 1-6), otherwise faults will not display unless the [\*] key is pressed.
- 4219/4229 modules must use EOLRs or unpredictable results may occur.
- RF Zones: The "open" option in entries 1, 3, and 5 is not applicable for RF zones. Use the "intact EOL" option for normal RF zone conditions and "shorted" for off-normal RF zone conditions.
- Zone-Doubling/Double-Balanced: A short on either zone of a zone-doubled pair or on a double-balanced zone causes a tamper condition.
  - For double-balanced zones, this entry must be "0."
  - For zone-doubled zones, **both** zones of the doubled pair must be assigned

## \*56 ZONE PROGRAMMING MENU MODE

(press \*56 while in Program mode) The Zone Programming Worksheet is on page 44.

### Zones and Partitions

Each protection zone needs to be programmed with various attributes using \*56 Zone Programming mode or \*58 Expert Programming Mode. Using this mode, enter the zone number to be programmed and make appropriate entries at the prompts. Finally, Confirm the serial number of wireless transmitter zones.

The VISTA-20P system can control two independent areas of protection (known as partitions) for use by independent users, if desired, by simply assigning zones to one or the other partition during zone programming. The VISTA-20P, by default, automatically distributes users between the two partitions. The master user can change the user number distributions.

Zones can also be assigned to a common partition, which is an area shared by users of both partitions (such as a lobby in a building). This allows either partition to arm, while leaving the common partition disarmed for access into the other partition.

The following describes the functioning of the VISTA-20P common partition:

- The common zone sounds and reports alarms only when both partitions are armed. If only one partition is armed, the system ignores faults on the common zone.
- Either partition may arm its system if the common zone is faulted, but once armed, the other partition will not be able to arm unless the common zone is first bypassed or the fault is corrected.
- Faults on the common zone are displayed on common zone keypads, and will also appear on another partition's keypad when that partition is armed.
- Either partition can clear and restore the common zone after an alarm.

### \*56 Menu Mode

PROMPT	VALID ENTRIES	EXPLANATION
<div style="border: 1px solid black; padding: 5px;">                     SET TO CONFIRM?                      0 = NO 1 = YES 0                 </div>	<b>Confirm?</b> 0 = no 1 = yes [*] to continue	This display appears upon entry into this mode. The default is 0 (No).  If 1 (Yes) is entered, you will be prompted to confirm each transmitter after entering the serial and loop numbers (at the "XMIT TO CONFIRM" prompt later).
<div style="border: 1px solid black; padding: 5px;">                     Enter Zn Num.                      (00 = Quit) 10                 </div>	<b>Zone Number</b> VISTA-20P: wired 01-08 (and 09-48 <sup>†</sup> ); wireless 09-48; RF button zones 49-64 VISTA-15P: wired 01-06 (and 09-24 <sup>†</sup> ); wireless 09-34; RF button zones 49-56 Both Controls: 91 = addr. device report enable 92 = duress report enable 95, 96, 99 = emerg. zones [*] to continue 00 to quit	Enter the zone number that you wish to program. Zone 10 has been entered in the example display at left. Enter a report code for zone 91 to enable addressable device reporting. Enter a report code for zone 92 to enable duress reporting. 95, 96, 99 are emergency (panic) key zones.  † if zone expanders are used.
<div style="border: 1px solid black; padding: 5px;">                     Zn ZT P R C In: L                      10 00 1 10 RF: 1                 </div>	<b>Summary Screen</b> [*] to continue	"IN: L" appears for wireless zones and indicates input type and loop. "IN: AD" appears for hardwire expansion zones (AW) and indicates the module's address (AD), which is based on the zone number. "HW: RT" appears for hardwire zones and indicates configuration (EOL, NO, NC, zone doubling, double-balanced) and response time selection.
<div style="border: 1px solid black; padding: 5px;">                     10 Zone Type                      Perimeter 03                 </div>	<b>Zone Type (ZT)</b> See table at right.	Each zone must be assigned to a zone type, which defines the way in which the system responds to faults in that zone. Enter the Zone Type code from the list below: <b>Note:</b> If 00 is entered, <b>Delete Zone ?</b> will be displayed. 00 = Not used            07 = 24-Hr Audible        20 = Arm-STAY* 01 = Entry/exit #1      08 = 24-Hr Aux            21 = Arm-AWAY* 02 = Entry/exit #2      09 = Fire                    22 = Disarm* 03 = Perimeter            10 = Interior w/Delay      23 = No Alarm Resp 04 = Interior Follower    12 = Monitor Zone         24 = Silent Burglary 05 = Day/Night            14 = Carbon Monoxide     77 = Keypad 06 = 24-Hr Silent        16 = Fire w/Verify        81 = AAV Mon. Zone *5800 button-type transmitters only
<div style="border: 1px solid black; padding: 5px;">                     10 Partition  <span style="float: right;">1</span> </div>	<b>Partition No. (P)</b> (VISTA-20P) 1-3 = partition (3 = common) [*] to continue	Enter the Partition number for this zone. Partition 1 is shown entered.

10 Report Code
1st 01 2nd 00 10

**Report Code (RC)**  
 First Digit: 1-9, 10 for 0, 11 for B, 12 for C, 13 for D, 14 for E, 15 for F  
 00 to disable  
 Second Digit: same as above  
 [\*] to continue

Enter the report code for this zone, which consists of 2 hexadecimal digits, each in turn consisting of 2 numerical digits. For example, for a report code of "10," enter 01 and 00. For Contact ID®, entering any non-zero entry as the first digit enables the report code for this zone.

02 HARDWIRE TYPE
EOL 0

**Hardwire Type**  
 0 = EOL  
 1 = NC  
 2 = NO  
 3 = zone doubling (ZD) †  
 4 = double-balanced (DB) †  
 [\*] to continue

This prompt appears only for zone numbers 02-08. Zone 1 is automatically set for EOL operation.

† VISTA-20P

02 Response Time
1

**Response Time (RT)**  
 0 = 10mSec;  
 1 = 350mSec  
 2 = 700mSec  
 3 = 1.2 seconds  
 [\*] to continue

Appears only for hardwire zones 01-08 (zone 02 is the display shown).  
 Option 3: used for "clean me" option on zone 1 (see field \*174).  
**NOTE:** If zone doubling is being used, the response time selected for zones 02-08 automatically applies to each zone's associated doubled zone.

10 INPUT TYPE
RF TRANS 3

**Input Device type (In)**  
 2 = AW (Aux wired zone)  
 3 = RF (supervised RF transmitter)  
 4 = UR (unsupervised RF transmitter)  
 5 = Button type RF transmitter (unsupervised).  
 [\*] to continue

This prompt is skipped for zones 2-8, or 2-16 if zone-doubling was enabled at "Hardwire Type" prompt.

All of the RF transmitters have one or more unique factory-assigned input (loop) ID codes. Each of the inputs requires its own programming zone (e.g., a 5804's four inputs require four programming zones).

RF Transmitters can be enrolled as one of the following types:

Type	Description
<b>RF</b> (Supervised RF)	Sends periodic check-in signals, as well as fault, restore, and low-battery signals. The trans. must stay within receiver's range.
<b>UR</b> (Unsupervised RF)	Sends all the signals that the "RF" type does, but the control does not supervise the check-in signals. The transmitter may therefore be carried off-premises.
<b>BR</b> (Unsupervised Button RF)	Sends only fault signals. It will not send a low-battery signal until it is activated. The transmitter may be carried off-premises.

**NOTE:**

- For the built-in hardwired zones, the Input Device type is automatically displayed as HW and cannot be edited.
- To change the input type of a previously programmed wireless device (type RF, UR, BR) to a wired zone (type AW), you must first delete transmitter's serial number (see To Delete A Serial Number prompt)

10 INPUT S/N: L
A022-4064 1

**Input Serial number and Loop Number**  
 [\*] to continue  
 Used only when enrolling wireless transmitters.

Enroll the transmitter's serial number and loop number as follows:

1. a. Transmit two open/close sequences (for button-type trans, press and release the button twice, waiting about 4 secs before pressing the button the second time).  
 OR  
 b. Manually enter the 7-digit serial number printed on the label of the transmitter. Press the [\*] key to move to the "L" position, then enter the loop number.  
 Use the [A] (Advance) and [B] (Back) keys to move the cursor forward and back within the screen. Pressing the [C] (Copy) key will insert the previously enrolled serial number, if desired (used when programming a transmitter with several input loops).

To delete an existing serial number, enter 0 in the loop number field. The serial number will change to 0's. If 0 was entered in error, simply re-enter the loop number or press [#], and the serial number will return to the display.
---

2. Press [\*] to continue. The system now checks for a duplicate serial/loop number.  
 If no duplicate is found, the display shows the serial number and loop number.
3. Press [\*] to continue to confirmation screen.

<pre>10 INPUT S/N   L A022-4064     ?</pre>	<p><b>Loop Number Change</b> [*] to continue</p>	<p><b>NOTE:</b> If the [C] key is used to copy the previously enrolled serial number, the cursor will move to the Loop column (L) with the previous serial number displayed, and display a highlighted question mark for the loop number.</p> <p>Enter the loop number and press [*]. The system will now check for a duplicate serial/loop number combination.</p>
<pre>XMIT TO CONFIRM PRESS * TO SKIP</pre>	<p><b>Confirmation Option</b> [*] to continue</p>	<p>This prompt will only appear if you answered “Yes” at the first prompt in this section.</p> <p>The system will enter a confirmation mode so that the operation of the actual programmed input can be confirmed.</p> <p>Activate the loop input or button that corresponds to this zone.</p>
<pre>Entd A022-4063 1 Rcvd A022-4064 1</pre>	<p><b>If Serial or Loop Numbers do not match after activating the transmitter</b> [*] to continue</p>	<p>If the serial number transmitted does not match the serial number entered, a display similar to the one shown appears. If the loop number does not match, it will also be displayed.</p> <p>If so, activate the loop input or button on the transmitter once again. If a match is not obtained (i.e., summary display does not appear), press the [#] key twice and then enter (or transmit) the correct serial number.</p>
<pre>10 INPUT S/N:   L A000-0000     0</pre>	<p><b>To Delete a Serial No.</b> 0 = delete serial number # = undo deletion [*] to continue</p>	<p>To delete an existing serial number, enter 0 in the loop number field. The serial number will change to 0's.</p> <p>If 0 was entered in error, simply re-enter the loop number or press [#], and the serial number will return to the display.</p>
<pre>Zn  ZT  RC  In:  L 10  03  10  RF:  1s</pre>	<p><b>Summary Screen</b> [*] to continue</p>	<p>If the serial number transmitted matches the serial number entered, the keypad will beep 3 times and a summary display will appear, showing that zone's programming. Note that an “s” indicates that a transmitter's serial number has been enrolled.</p> <p>Press [*] to accept the zone information and continue.</p>
<pre>PROGRAM ALPHA? 0 = NO 1 = YES  0</pre>	<p><b>Alpha Descriptors</b> 0 = no 1 = yes [*] to continue</p>	<p>If you want to program descriptors for zones now, enter 1 (Yes) and refer to the *82 Descriptor Programming section for available descriptors.</p>
<pre>ENTER ZN NUM. (00 = QUIT)  11</pre>	<p><b>Next Zone Number</b> [*] to continue; 00 = quit</p>	<p>If 0 (No) was entered above, the system will return you to the ENTER ZN NUM. prompt for the next zone.</p> <p>When all zones have been programmed, enter 00 to quit</p>

### Completing Zone Programming

- When you have finished programming all zones, test each zone using the system's TEST mode.
- **Do not use the Transmitter ID Sniffer Mode for checking wireless transmitting devices**, as it will only check for transmission of one zone on a particular transmitter, NOT the zones assigned to each additional loop.

## \*58 EXPERT ZONE PROGRAM MODE

(press \*58 while in Data Programming mode)

This method is designed for use by installers with previous experience in programming HONEYWELL control panels. This mode is also used to program wireless keys using pre-defined templates.

<pre>SET TO CONFIRM? 0 = NO 1 = YES  0</pre>	<p><b>Confirm?</b> 0 = no; 1 = yes; [*] to continue</p>	<p>Select whether you want confirmation of wireless device enrollment. (See “XMIT TO CONFIRM” prompt later in this section.) <b>We recommend that you confirm the programming of every transmitter.</b></p> <p>If 1 (Yes) is entered, you will be prompted to confirm each transmitter after entering the serial and loop numbers (at the “XMIT TO CONFIRM” prompt later).</p>
<pre>Zn  ZTP RC HW: RT 01  09  1  10  EL  1</pre>	<p><b>Summary Screen</b> 01-64 = zone number; [*] to continue; 00 = quit [D] to go to prompts for wireless key programming templates</p>	<p>A summary screen appears, showing zone 1's currently programmed values.</p> <p>Enter the zone number being programmed, then press [*], which displays a summary screen for that zone and the cursor moves to the Zone Type location. The cursor then automatically moves to the next locations after each entry is made.</p> <p><b>If programming a wireless key</b>, press the [D] key then skip to the Wireless Key Programming Templates section following this section. When [D] is pressed, you can choose from a series of preset templates for easy programming of wireless key zones.</p> <p>When all zones have been programmed, press 00 at this prompt to quit this menu mode.</p>

Zn	ZT	P	RC	IN:	L
10	00	1	10	RF	1

### Zone Programming

ZT = see Zone Type chart shown in \*56 Menu Mode "Zone Type" prompt  
P = partition 1, 2, 3 (common);  
RC = 1 (send CID report); 0 (no report)  
IN = input type;  
L = loop number  
[\*] to continue

A summary screen with the selected zone's current programming appears.

Begin programming zone information as follows:

- Enter Zone Type (ZT), Partition (P), Report Code (RC; 0-9 only; use \*56 mode to enter hex codes), and Input Device Type (IN)\* sequentially, but not the Loop No. (L).
- Use the [A] (Advance) and [B] (Back) keys on the keypad to move the cursor within the screen.
- Use the [C] key to copy the previous zone's attributes.

Press [\*] to save the programming and continue to the serial number/loop number prompt. If needed, you can press the [#] key to back up without saving.

\* If HW (hardwired) or AW (Auxiliary) is entered for Input Device Type, the next screen will be similar to the prompt shown, except that HW or AW will be displayed under "IN".

If RF, BR, or UR is entered, a prompt for Serial and Loop number will be displayed, as described in \*56 Menu mode section.

When done, the display returns to the initial summary screen prompt to let you program the next zone.

**To exit this mode**, enter 00 at the Summary Screen prompt.

## WIRELESS KEY PROGRAMMING TEMPLATES

(press the [D] key from \*58 Menu mode Summary Screen)

This procedure programs the wireless keys, **but a key is not active for arming/disarming until it is assigned to a user number** (see **System Operation** section, Assigning Attributes Command in the User Guide).

TEMPLATE ?	
1-6	1

### Template Number

1-3 = 5804 templates; 4-6 = 5804BD templates

- Enter Template number 1-6 (see chart on next page). See the defaults provided for each template in the chart that follows these procedures.
- Select from templates. Press [\*] to display template (1 shown selected).  
**NOTE:** If necessary, press [#] to back up and re-enter template number.
- Press [#] if you want to return to \*58 Menu mode summary screen.

L	01	02	03	04
T	23	22	21	23

### Template Display

- When [\*] is pressed, the selected template will be displayed. Top line of display represents loop numbers; bottom line represents zone type assigned for each loop.
- Press [\*] to accept template.

PARTITION	
	1

### Partition

VISTA-20P. 1 = partition 1; 2 = partition 2

- Enter the partition in which the key is to be active, then press [\*] to continue.

ENTER START ZONE	
00 = QUIT	36

### Start Zone Number

- The system will search for the highest available consecutive 4-zone group (the four zones in the case of the 5804 and 5804BD), and display the lowest zone number of the group. If you want to start at a different zone, enter the zone desired, and press [\*]. If that zone number is displayed, the system has the required number of consecutive zones available, beginning with the zone you entered. If not, the system will again display a suggested zone that can be used. If the required number of consecutive zones is not available at all, the system will display "00".

**To quit this mode** and return to \*58 Menu mode, enter 00 at this prompt.

- Press [\*] to accept.

INPUT S/N	L
Axxx-xxxx	-

### Serial Number

- Manually enter the serial number printed on the label for the wireless key or press and release the button to transmit its serial number.
- Press [\*] to accept the serial number. The system will check for a duplicate.
- If necessary, press the [#] key to back up without saving, and re-enter the serial number.
- Use the [A] key to move forward within the screen, and the [B] key to move backward.

XMIT TO CONFIRM  
PRESS \* TO SKIP

**Confirm**  
[\*] to continue

- If "Yes" was entered at the **SET TO CONFIRM?** prompt previously (see first prompt following entry into the \*58 Expert Programming Mode), the display on the left will appear. Confirm serial and loop numbers by activating the wireless key.

**IMPORTANT:**

When confirmed, the key is not active for arming/disarming until it is assigned to a user number (using the assigning attributes command, attribute "4"). See **System Operation** section for procedure.

Entd A022-4063  
Rcvd A022-4064

**Not Confirmed**  
[\*] to continue

If the serial number transmitted does not match the serial number entered, a display similar to the one shown will appear. If the loop number does not match, it will also be displayed. If so, activate the button on the wireless key once again. If a match is not obtained (i.e., summary display does not appear), press the [#] key and then enter the correct serial number.

If the serial number transmitted matches the serial number entered, the keypad will beep 3 times and will return you to the Zone Number prompt to enter the starting zone for the next wireless key.

Or you can return to \*58 Menu mode by pressing 00 at the Zone Number prompt.

**Wireless Key Predefined Default Templates**

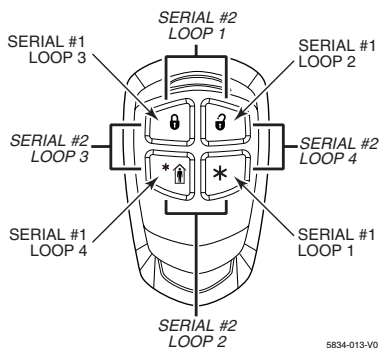

**5834-4 Wireless Key Transmitter**

5834-013-V0

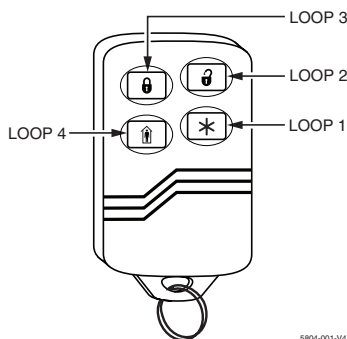

**5804 Wireless Key Transmitter**

5804-001-V4

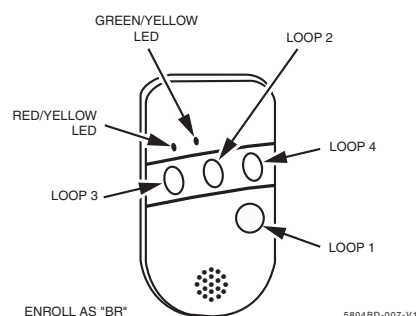

**5804BD 2-Way Wireless Key Transmitter**

5804BD-007-V1

**NOTE:** Some transmitters are not intended for use in UL installations.

TEMPLATE 1	For Button-Type Devices			TEMPLATE 4	For Button-Type Devices		
	Loop	Function	Zone Type		Loop	Function	Zone Type
	1	No Response	23		1	No Response	23
	2	Disarm	22		2	No Response	23
	3	Arm Away	21		3	Arm Away	21
	4	No Response	23		4	Disarm	22
TEMPLATE 2	Loop	Function	Zone Type	TEMPLATE 5	Loop	Function	Zone Type
	1	No Response	23		1	No Response	23
	2	Disarm	22		2	Arm Stay	20
	3	Arm Away	21		3	Arm Away	21
	4	Arm Stay	20		4	Disarm	22
TEMPLATE 3	Loop	Function	Zone Type	TEMPLATE 6	Loop	Function	Zone Type
	1	24-hour audible	7		1	24-hour audible	7
	2	Disarm	22		2	Arm Stay	20
	3	Arm Away	21		3	Arm Away	21
	4	Arm Stay	20		4	Disarm	22

**Deactivating & Removing a Wireless Key from the System**

Deactivate a wireless key by deleting the associated user code:

Delete the User Code: Master code + [8] + 2-digit user no. + [#] [0]

Remove a wireless key from the system by deleting one of the wireless key zones using Zone Programming mode:

- Press \*56 while in Program mode then enter a zone number assigned to the wireless key.
- Scroll through each prompt by pressing [\*] until the Input S/N prompt appears.
- Enter 0 for the loop number and press [\*].
- Exit program mode.

## \*57 FUNCTION KEY PROGRAMMING MENU MODE

(press \*57 while in Data Programming mode) The Function Key Worksheet is on page 45.

The system provides the ability to program each of the four keypad function keys to perform one of 12 system operations. The end user can then activate the function by simply pressing and holding the programmed key for 2 seconds. Typical functions (listed below) include single-button arming, turning lights on/off, or single-button paging.

To assign emergency key functions (function key option "00"), first program the respective emergency zone number (95 for "A" key, 96 for "C" key, 99 for "B" key) with the desired zone type using \*56 (or \*58) Zone Programming mode, then use \*57 Function Key menu mode to assign the desired key.

To use a function key to activate a relay action (\*57 Menu mode key function 07), use \*79 Menu mode to map the output, and use \*80 Menu mode to define the output's action; select system operation type "66."

To use a function key for a user macro, use \*57 menu mode to activate the desired key, then define the actual macro functions using the user code + [#] + [6] [6] command.

Press Key to Pgm	
0 = Quit	0

### Function Key

Press the desired function key, A-D.

[\*] to continue  
0 = Exit this mode

Press the desired function key (A-D) you want to program.

**NOTE:** A key programmed as a function key is no longer available to be used as an end-user macro key or panic key.

A	→	<input type="text"/>	1 OFF	2 AWAY	3 STAY
B	→	<input type="text"/>	4 MAX	5 TEST	6 BYPASS
C	→	<input type="text"/>	7 INSTANT	8 CODE	9 CHECK
D	→	<input type="text"/>	* READY	0	#

keypad-keys-00-001-V10

Partition	
	1

### Partition Number (VISTA-20P)

1 = partition 1  
2 = partition 2  
3 = common partition  
[\*] to continue

Enter the partition in which the function key is active.

Key "A" Func	
Zone 95	00

### Define Key Function

00-12 = see list at right  
[\*] to continue; returns to key number prompt with the next function key letter displayed

Enter the desired function for this key, 00 to 12, from the options listed. (00 selected for example display shown at left). Press [\*] to returns to key number prompt with the next function key letter displayed.

00† = For the Function key selected, the functions are predefined as follows:

If A selected = Zone 95 (emergency key, same as [1] [\*] pair)

If B selected = Zone 99 (emergency key, same as [\*] [#] pair)

If C selected = Zone 96 (emergency key, same as [3] [#] pair)

If D selected = Single-button paging

01 = Single-button paging (sends a 999-9999 message to pager)

02 = Display time

03 = Arm AWAY (reports as User 00 if closing reports are enabled)

04 = Arm STAY (reports as User 00 if closing reports are enabled)

05 = Arm NIGHT-STAY (reports as User 00 if closing reports are enabled)

06 = Step Arming (arms STAY, then NIGHT-STAY†††, then AWAY)

07 = Output Device Command (for device programmed as system operation type 66–function key in \*80 Menu Mode)

08 = Communication Test (sends Contact ID code 601)

09 = Macro Key 1 (define macro by user code + [#] [6] [6] command)

10 = Macro Key 2 (define macro by user code + [#] [6] [6] command)

11†† = Macro Key 3 (define macro by user code + [#] [6] [6] command)

12†† = Macro Key 4 (define macro by user code + [#] [6] [6] command)

† System defaults to these function key settings.

†† Macros 11-12 apply to VISTA-20P only.

††† If Night-Stay zones are listed in zone list 5



## OUTPUT DEVICE PROGRAMMING GENERAL INFORMATION (\*79/\*80 Menu Mode)

**Output Devices:** The VISTA-20P system supports up to 16 relays and/or Powerline Carrier devices (X-10 devices) plus 2 built-in trigger outputs in any combination. These 18 “outputs” are assigned to system-wide output numbers (01-18). Use \*79 Menu Mode to assign output numbers and map them to device addresses.

The VISTA-15P supports 8 relays and 2 built-in trigger outputs (total 10 outputs).

**Output Functions:** The system also provides installer-defined output functions, which can be assigned to any of the physical outputs. Therefore, the action of any one of the outputs can be based on as many of these defined functions as desired. This lets a single relay or X-10 device perform many functions.

The control supports: V20P = up to 48 defined functions; V15P = up to 24 functions

Use \*80 Menu Mode to define output functions.

**WARNING:** Relays and output devices are not recommended for life safety applications.

**NOTE:** When navigating the \*79 and \*80 menus: The [\*] key is used to accept an entry and advance to the next prompt. The [#] key is used to revert back to the last question to check or change an entry. Press [\*] to go forward again.

### Programming Output Devices

1. Use \*79 Menu Mode to assign module and output numbers and map them to device addresses.

**NOTE:** You must map output devices using \*79 Menu Mode **before** you can use \*80 menu Mode.

2. Use \*80 Menu Mode to create output definitions, which control the output devices, if desired.

3. Use \*81 Zone List Menu mode to define zone lists for use with output devices if the device action is based on more than one zone.

- To program a device for manual activation (user code + [#] [7] / [#] [8] + 2-digit device number) or for scheduled automatic activation, simply map the device using \*79 Menu mode.
- To program a device to automatically activate upon a system event (or function key), use \*79 Menu mode to map the device, then use \*80 Menu mode to define the automated device action.

## \*79 RELAY/POWERLINE CARRIER DEVICE (X-10) PROGRAMMING MENU MODE

(press \*79 while in Programming mode) The \*79 Device Mapping Worksheet is on page 45.

Use this menu to assign Relay Module device addresses and specific relay numbers, and Powerline Carrier unit numbers. The system is based on predefined module addresses for 4204 and 4229 modules. Refer to the table shown at the “Module Address” prompt on the next page and set the modules’ addresses (via module DIP switches) accordingly.

The following table shows how these outputs are identified.

### Output Identification

This output...	is identified by...
Relays	the Relay Module’s device address and the relay position on that module (i.e. the physical relay number, 1-4, on that module).
X-10 Device	a house ID (entered in data field *27) and the unit number of the device.
Built-in Outputs	the output number assigned, 17 for Trigger 1 and/or 18 for Trigger 2.

ENTER OUTPUT NO. 00 = QUIT                      xx	<b>Device Output Number</b> VISTA-20P: 01-16 = relays/X-10 17, 18 = on-board triggers  VISTA-15P: 01-08 = relays/X-10 17, 18 = on-board triggers [*] to continue 00 to quit	This is the logical (or reference) relay number as used in the system. Relays and X-10 devices are numbered 01-16; the on-board triggers are numbered 17 and 18 and can be programmed for inverted output, if required.
---	--	---

17 OUT NORM LOW 0 = NO 1 = YES                      0	<b>Output Normally Low</b> 0 = no (standard default) 1 = yes [*] to continue	(prompt appears only if trigger 17 or 18 was selected above) Selecting 0 (no) sets the output level normally high (default setting). Selecting 1 (yes) sets the output normally low. Output Trigger 17 can be used for resetting 4-wire smoke detectors† by connecting it to the negative power terminal of the smoke detector, selecting 1 at this prompt, and setting as zone type 54, fire zone reset, in *80 Menu mode. After entry, display returns to Output Number prompt. Use *80 Menu mode to program the function of the trigger.
--	---	---

† **Power Reset:** This control does not automatically reset power to 4-wire smoke detector zones, so you must use a relay (e.g., 4204, 4229) or on-board trigger to reset power (also required for fire verification).

XX OUTPUT TYPE DELETE                    0	<p><b>Output Type</b> 0 = delete 1 = relay on 4204/4229 2 = Powerline Carrier Device [*] to continue</p>	<p>Select whether this is a relay or a Powerline Carrier (X-10) device. If Powerline Carrier Device (X-10) is selected, go to "A" prompt. If relay is selected, skip to "B" prompt.</p>																				
"A" XX UNIT No. yy	<p><b>Unit Number</b> 01-16 = predefined address [*] to continue</p>	<p>(prompt appears if X-10 is selected) Enter the unit code (set at the device) and press [*]. The system returns to the Output Number prompt.</p>																				
"B" XX MODULE ADDR 07-15                    yy	<p><b>Module Address</b> 07-15 = predefined address [*] to continue</p> <p><b>REMOTE SERVICES NOTE:</b> If using the communication device's Multi-Mode 4204 or 2-4204 options, select one of the 4204 addresses, though a physical 4204 module is not installed. If using 2-4204 multi-mode option, the second 4204 address is automatically one number higher than the first address. Make sure these addresses are not used by physical 4204 modules that may be installed. If using Multi-Mode Enhanced Reports option, RIS must be enabled in field *91; when enabled, address 25 is automatically assigned. See the communication device's instructions to enable Multi-Mode.</p>	<p>(prompt appears if relay is selected) Enter the predefined address for this module as listed below. Make sure the module's DIP switches are set to the selected address.</p> <p><b>Module Addresses</b></p> <table border="1" style="width: 100%; border-collapse: collapse;"> <thead> <tr> <th style="text-align: left;">Address</th> <th style="text-align: left;">Module</th> </tr> </thead> <tbody> <tr><td>07</td><td>1st 4229 (with zones 09-16)</td></tr> <tr><td>08</td><td>2nd 4229 (with zones 17-24)</td></tr> <tr><td>09†</td><td>3rd 4229 (with zones 25-32)</td></tr> <tr><td>10†</td><td>4th 4229 (with zones 33-40)</td></tr> <tr><td>11†</td><td>5th 4229 (with zones 41-48)</td></tr> <tr><td>12</td><td>1st 4204</td></tr> <tr><td>13</td><td>2nd 4204</td></tr> <tr><td>14†</td><td>3rd 4204</td></tr> <tr><td>15†</td><td>4th 4204</td></tr> </tbody> </table> <p>† These addresses apply to VISTA-20P only.</p>	Address	Module	07	1st 4229 (with zones 09-16)	08	2nd 4229 (with zones 17-24)	09†	3rd 4229 (with zones 25-32)	10†	4th 4229 (with zones 33-40)	11†	5th 4229 (with zones 41-48)	12	1st 4204	13	2nd 4204	14†	3rd 4204	15†	4th 4204
Address	Module																					
07	1st 4229 (with zones 09-16)																					
08	2nd 4229 (with zones 17-24)																					
09†	3rd 4229 (with zones 25-32)																					
10†	4th 4229 (with zones 33-40)																					
11†	5th 4229 (with zones 41-48)																					
12	1st 4204																					
13	2nd 4204																					
14†	3rd 4204																					
15†	4th 4204																					
XX REL POSITION 1-4                            zz	<p><b>Relay Position</b> 1-4 = relay position [*] to continue</p>	<p>This is the actual (or physical) relay number with respect to the Relay Module upon which it is located. For 4204 modules, relay numbers are 1-4. For 4229 modules, relay numbers are 1-2. The system returns to the Output Number prompt for programming the next device.</p> <p><b>REMOTE SERVICES NOTE:</b> If using the communication device's multi-mode, program virtual 4204 relays to trigger on those system events intended to be sent to the user's email address. (4204 option = up to 4 events; 2-4204 option = up to 8 events)</p>																				

## \*80 OUTPUT FUNCTION MENU MODE

(press \*80 while in Programming mode) The Output Definition Worksheet is on page 46.

Use this mode to program output function definitions (up to 48 functions) that provide automated control of any of the output devices, based on events occurring on individual zones or zones with certain zone types. Each output definition is identified by an output function number, and includes the following components:

### Output Definition Components

Component	Description
Output Function No.	A reference number that defines an output's characteristics.
Activated By	Determines whether the initiating event occurs on a zone, a zone list, or a zone type.
Event	Event that triggers the output action. Can be an event occurring on a specific zone number or a zone list, or a specific zone type.
Partition	If the output is activated by zone type, this defines the partition in which the programmed event is to cause the device action.
Output Action	Defines the action of the relay/X-10 device when the defined event occurs. Can close for 2 seconds, stay closed until reset, continuously pulse (1-second close-open-close-open, etc.), toggle the device state, or activate for a defined duration (set in data field *177).
Output No.	Assigns this function to a specific output number (defined in *79 Menu Mode). This is the output number that will perform this function upon the triggering event. Note that each defined function is associated with only one output number. This means that if more than one output device needs to perform this particular function, you need to define another output function number with the same attributes, but assign the appropriate output number. (i.e. output devices can be assigned more than one function number, but each function number can only be assigned a single output number.

**For example,** if you want to pulse a strobe light upon fire alarms on zone 4 using a relay mapped to output number 2 (as programmed in \*79 Menu Mode), program the following in \*80 Menu Mode:

Prompt	Entry
Output Funct. #	= 01 (assuming this is the first output function)
Activated By:	= 3 (zone number)
Enter Zn No.	= 04 (requires 2-digit zone numbers)
Output Action	= 3 (continuous pulse)
Output Number	= 02 (device mapped in *79 Menu Mode)

## 80 Menu Mode

Output Funct. # (00 = Quit)      01	<b>Output Function No.</b> (VISTA-20P: 01-48 (VISTA-15P: 01-24) [*] to continue; 00 to quit	Enter the output function number to be defined (or 00 to exit)																																																			
01 A E P Trig ?00 0 0 - ZL=00	<b>Summary Screen</b> [*] to continue	This screen displays a summary of the current output programming (for this example, Zone List has been selected-this is the default screen). <b>A</b> = Output Action; <b>E</b> = Triggering event; <b>P</b> = Partition; <b>Trig</b> = Trigger type <b>NOTE:</b> A question mark in the summary screen indicates that the device number shown has not been mapped. Use *79 Menu mode to map the device.																																																			
01 Activated By: Zone List	<b>Activated By</b> 0 = delete 1 = zone list (go to "A") 2 = zone type (go to "B") 3 = zone number (go to "C") [*] to continue	Select where the initiating event for this output definition is to occur as follows: If you enter "0," the following prompt appears: <div data-bbox="776 529 1042 592" style="border: 1px solid black; padding: 2px; width: fit-content;">           Delete?            0 = NO, 1 = YES         </div> Press 1 to delete this output definition. The system deletes the output function and any previous programming.																																																			
<b>A"</b> <div data-bbox="147 688 412 760" style="border: 1px solid black; padding: 2px;">           01 Zn List      1         </div>	<b>Zone List</b> 01-08 = zone list [*] to continue	(prompt appears if zone list was selected) Enter the desired zone list number associated with this output number. At the ENTER EVENT prompt, enter the zone list event that will activate this output <b>NOTE:</b> Do not use pager zone lists 09-12 in output definitions. <div data-bbox="776 802 1042 865" style="border: 1px solid black; padding: 2px; width: fit-content;">           Enter Event      0 = restore; 1 = alarm;            Alarm            2 = fault; 3= trouble         </div> <b>NOTE:</b> For alarm, fault, and trouble, an event on ANY zone in the list activates the output, but ALL zones in the list must be restored before the output is restored. Press [*] to continue and skip to the "Output Action" prompt.																																																			
<b>"B"</b> <div data-bbox="147 1024 412 1096" style="border: 1px solid black; padding: 2px;">           01 Enter Zn type            Perimeter      03         </div>	<b>Zone Type</b> See list at right for available zone types.	(prompt appears if zone type was selected) Enter the desired zone type associated with this output number. At the PARTITION prompt, enter the partition in which this zone type will occur. <b>CHOICES FOR ZONE TYPES:</b> <table border="0" style="width: 100%;"> <tr> <td>00 = Not Used</td> <td>05 = Day/Night</td> <td>12 = Monitor Zone</td> </tr> <tr> <td>01 = Ent/Exit #1</td> <td>06 = 24 Hr Silent</td> <td>14 = Carbon Monoxide††</td> </tr> <tr> <td>02 = Ent/Exit #2</td> <td>07 = 24 Hr Audible</td> <td>16 = Fire w/verification</td> </tr> <tr> <td>03 = Perimeter</td> <td>08 = 24 Hr Aux</td> <td>23 = No Alarm Response</td> </tr> <tr> <td>04 = Interior Follower</td> <td>09 = Fire</td> <td>24 = Silent Burglary</td> </tr> <tr> <td></td> <td>10 = Interior w/Delay</td> <td>77 = Keyswitch Zone</td> </tr> <tr> <td></td> <td></td> <td>81 = AAV Monitor Zone</td> </tr> <tr> <td></td> <td></td> <td>90-91 = Configurable</td> </tr> </table> <b>CHOICES FOR SYSTEM OPERATION:</b> <table border="0" style="width: 100%;"> <tr> <td>20 = Arming-Stay</td> <td>36 = **At Bell Timeout***</td> <td>58 = Duress</td> </tr> <tr> <td>21 = Arming-Away</td> <td>38 = Chime</td> <td>60 = AAV</td> </tr> <tr> <td>22 = Disarming</td> <td>39 = Any Fire Alarm</td> <td>61 = AVS/GSMV4G session begin §</td> </tr> <tr> <td>31 = End of Exit Time</td> <td>40 = Bypassing</td> <td>62 = AVS/GSMV4G session end §</td> </tr> <tr> <td>32 = Start of Entry Time</td> <td>41 = **AC Power Failure</td> <td>66 = Function Key†</td> </tr> <tr> <td>33 = Any Burglary Alarm</td> <td>42 = **System Battery Low</td> <td>67 = Bell Fail</td> </tr> <tr> <td></td> <td>43 = Comm. Failure</td> <td>68 = Telco Line Cut</td> </tr> <tr> <td></td> <td>52 = Kissoff</td> <td>78 = Keyswitch Red LED</td> </tr> <tr> <td></td> <td>54 = Fire Zone Reset</td> <td>79 = Keyswitch Green LED</td> </tr> </table> ** Use 0 (Any) for Partition No. (P) entry. *** Or at Disarming, whichever occurs earlier. † Use *57 Menu Mode to assign the function key (function "07"). †† when used with an output function, the carbon monoxide zone type activates upon CO alarms only. Does not activate for trouble conditions. § automatically set when appropriate AVS Quick Command performed. <b>Note:</b> In normal operation mode: Code + # + 7 + NN Key Entry <b>starts</b> Device NN. Code + # + 8 + NN Key Entry <b>stops</b> Device NN. Enter the partition in which this zone type will occur. <div data-bbox="776 1831 1042 1894" style="border: 1px solid black; padding: 2px; width: fit-content;">           01 Partition      0 = any partition; 1 = partition 1;            Any partition    2 = partition 2; 3 = common         </div> Press [*] to continue and skip to the "Output Action" prompt.	00 = Not Used	05 = Day/Night	12 = Monitor Zone	01 = Ent/Exit #1	06 = 24 Hr Silent	14 = Carbon Monoxide††	02 = Ent/Exit #2	07 = 24 Hr Audible	16 = Fire w/verification	03 = Perimeter	08 = 24 Hr Aux	23 = No Alarm Response	04 = Interior Follower	09 = Fire	24 = Silent Burglary		10 = Interior w/Delay	77 = Keyswitch Zone			81 = AAV Monitor Zone			90-91 = Configurable	20 = Arming-Stay	36 = **At Bell Timeout***	58 = Duress	21 = Arming-Away	38 = Chime	60 = AAV	22 = Disarming	39 = Any Fire Alarm	61 = AVS/GSMV4G session begin §	31 = End of Exit Time	40 = Bypassing	62 = AVS/GSMV4G session end §	32 = Start of Entry Time	41 = **AC Power Failure	66 = Function Key†	33 = Any Burglary Alarm	42 = **System Battery Low	67 = Bell Fail		43 = Comm. Failure	68 = Telco Line Cut		52 = Kissoff	78 = Keyswitch Red LED		54 = Fire Zone Reset	79 = Keyswitch Green LED
00 = Not Used	05 = Day/Night	12 = Monitor Zone																																																			
01 = Ent/Exit #1	06 = 24 Hr Silent	14 = Carbon Monoxide††																																																			
02 = Ent/Exit #2	07 = 24 Hr Audible	16 = Fire w/verification																																																			
03 = Perimeter	08 = 24 Hr Aux	23 = No Alarm Response																																																			
04 = Interior Follower	09 = Fire	24 = Silent Burglary																																																			
	10 = Interior w/Delay	77 = Keyswitch Zone																																																			
		81 = AAV Monitor Zone																																																			
		90-91 = Configurable																																																			
20 = Arming-Stay	36 = **At Bell Timeout***	58 = Duress																																																			
21 = Arming-Away	38 = Chime	60 = AAV																																																			
22 = Disarming	39 = Any Fire Alarm	61 = AVS/GSMV4G session begin §																																																			
31 = End of Exit Time	40 = Bypassing	62 = AVS/GSMV4G session end §																																																			
32 = Start of Entry Time	41 = **AC Power Failure	66 = Function Key†																																																			
33 = Any Burglary Alarm	42 = **System Battery Low	67 = Bell Fail																																																			
	43 = Comm. Failure	68 = Telco Line Cut																																																			
	52 = Kissoff	78 = Keyswitch Red LED																																																			
	54 = Fire Zone Reset	79 = Keyswitch Green LED																																																			

<p><b>"C"</b></p> <p>01 Enter Zn No. <span style="float: right;">12</span></p>	<p><b>Zone Number</b> Press [*] to continue.</p>	<p>(prompt appears if zone number was selected) Enter the desired zone number associated with this output number. At the ENTER EVENT prompt, enter the zone event that will activate this output.</p> <p>01 Enter Event <span style="float: right;">0 = restore; 1 = alarm/fault/trouble</span> Restore <span style="float: right;">0</span></p>
<p>01 Output Action Close for 2 sec <span style="float: right;">1</span></p>	<p><b>Output Action</b> 0 = off 1 = Close for 2 seconds 2 = Stay Closed 3 = Pulse on &amp; off (1 sec ON, 1 sec OFF) 4 = Change Device State 5 = Duration 1 (see data field *177) 6 = Duration 2 (see data field *177) Press [*] to continue.</p>	<p>Press [*] to continue to the "Output Action" prompt Enter the desired device action.</p>
<p>Enter Output No. R02 <span style="float: right;">02</span></p>	<p><b>Output Number</b> 01-16 = VISTA-20P outputs 01-08 = VISTA-15P outputs 17-18 = on-board triggers Press [*] to continue.</p>	<p>Enter the device output number (programmed in *79 Menu Mode) you want associated with this output.</p>
<p>02 A E P TRIG R02 1 1 3 ZL=00</p>	<p><b>Summary Screen</b> Press [*] to continue.</p>	<p>A summary screen appears showing the programmed settings. Press [*] to return to OUTPUT FUNCTION NUMBER prompt</p>

## \*81 ZONE LIST MENU MODE

(press \*81 while in Programming mode) The Zone List Worksheet is on page 45.

Zone lists let you group individual zones for use with certain system actions. Using this mode, simply select an appropriate zone list number, then add the desired zone numbers to be included in that list.

The following table shows the available zone lists and their purposes:

List No.	Used for...	Notes
1, 2	general purpose (GP)	<ul style="list-style-type: none"> <li>Any list may include any or all of the system's zone numbers.</li> <li>A zone list can be assigned to more than one output relay.</li> <li>Zone List 4: When creating zone list 4 for cross zoning, include only zones assigned to zone types 3, 4, or 5. Do not include zones that have delays (entry/exit zones, interior w/delay) or 24-hour zones, as these zone types may produce unpredictable operation and may not function as intended. See field *85 for Cross Zone Timer option.</li> <li>Zone List 6: <b>V20PSIA/V15PSIA</b>: See field *50 for Dial Delay Disable option.</li> <li>Zone List 7: <b>V20PSIA/V15PSIA</b>: See field *93 for Unlimited Reports option.</li> </ul>
3	chime-by-zone (see field *26 to enable option)	
4	cross zones (see note at right)	
5	night stay zones	
6	general purpose <b>V20PSIA/V15PSIA</b> : dial delay disable	
7	general purpose <b>V20PSIA/V15PSIA</b> : unlimited reports	
8	general purpose	
9	zones that activate Pager 1	
10	zones that activate Pager 2	
11	zones that activate Pager 3 (VISTA-20P)	
12	zones that activate Pager 4 (VISTA-20P)	

### \*81 Menu Mode

<p>Zone List No. (00 = Quit) <span style="float: right;">01</span></p>	<p><b>Zone List Number</b> 01-12 = zone list number [*] to continue</p>	<p>Enter the Zone List Number to program (or 00 to quit). Press [*] to advance. In the following displays, zone list 01 has been selected.</p>
<p>01 Enter Zn Num. (00 = Quit) <span style="float: right;">00</span></p>	<p><b>Zone Number</b> 01-64<sup>†</sup> = zone numbers followed by [*] to accept each zone 00 to continue</p>	<p>Enter each zone number to add to the zone list, followed by pressing [*] (example, 01*, 02*, 03*). After all zones are entered, press 00 to continue. <b>IMPORTANT:</b> Do not include fire zones in zone lists that are used to STOP device actions. <sup>†</sup> VISTA-20P = 01-64; VISTA-15P = 01-06, 09-34, 49-56.</p>
<p>01 Del Zn List? 0 = No 1 = Yes <span style="float: right;">0</span></p>	<p><b>Deleting Zone Lists</b> 0 = don't delete list 1 = delete this zone list [*] to continue</p>	<p>To delete the zone list, enter 1. All zones in the zone list will be deleted automatically and the system returns to the Zone List No. prompt. To save the zone list, enter 0.</p>

<div style="border: 1px solid black; padding: 2px;"> 01 Delete Zone?  0 = No 1 = Yes 0 </div>	<b>Deleting a Zone</b> 0 = don't delete zones 1 = go to next prompt to delete zones [*] to continue	To save the zone list, enter 0 and the system returns to the Zone List No. prompt. To delete a zone or zones in a zone list, enter 1 to continue.
<div style="border: 1px solid black; padding: 2px;"> 01 Zn to Delete?  (00 = Quit) 00 </div>	<b>Delete the Zone</b> 01-64† = zones to be deleted from list followed by [*] to accept each zone 00 to continue	Enter each zone to be deleted from the list, followed by [*]. After all zones to be deleted are entered, enter 00 to return to the Zone List No. prompt so that another list can be programmed, if desired. † VISTA-20P = 01-64; VISTA-15P = 01-06, 09-34, 49-56.

## \*82 ALPHA DESCRIPTOR MENU MODE

The system lets you assign zone descriptors for protection zones, keypad panics, and RF receiver supervision faults. Each description can be composed of a combination of up to 3 words selected from a vocabulary of words stored in memory (see Alpha Vocabulary List page). In addition, up to 10 installer-defined words can be added to those already in memory, plus 3 additional words can be assigned as partition descriptors. Thus, when an alarm or trouble occurs in a zone, an appropriate description for that zone's location can be displayed at the keypad. Zone descriptors are recommended for systems using Alpha display keypads, and are necessary if a 4286VIP Phone Module is used.

**NOTE:** You can also enter zone descriptors when the zone is being defined in \*56 Menu mode.

**4286 NOTE:** If using a 4286VIP Phone Module, select from those words in the Alpha Vocabulary List shown in **boldface type**. The phone module will not provide annunciation of the other words.

If a Phone Module is added to an existing system, the Alpha descriptors presently in the system should be reprogrammed, selecting from those words shown in **boldface type** in the Alpha Vocabulary List. The phone module will not provide annunciation of any other words.

### \*82 Menu Mode

<div style="border: 1px solid black; padding: 2px;"> Program Alpha ?  0=No, 1=Yes 00 </div>	<b>Program Alpha</b> 0 = no (quit Alpha mode) 1 = yes [*] to continue	The "Program Alpha ?" prompt will appear. Press 1 to continue.
<div style="border: 1px solid black; padding: 2px;"> Custom Words ?  0=No, 1=Yes 00 </div>	<b>Custom Words</b> 0 = no 1 = yes	The "Custom Words" prompt will appear. Press 0 to program standard alpha descriptors from the fixed vocabulary. The system then automatically displays the descriptor for zone 1. Press 1 to define custom words (see "Adding Custom Words").
<div style="border: 1px solid black; padding: 2px;"> * ZN 01 </div>	<b>Summary Screen</b> [*] to continue to edit mode [#] = return to Program Alpha prompt (to quit)	Note that this is a "Summary mode," and that no entries can be made. Entries can be made only when the display contains a flashing cursor, which signifies Edit mode. To exit the Alpha Descriptor mode, press * + 0 + 0 at the summary display.
<div style="border: 1px solid black; padding: 2px;"> * ZN 01 □ </div>	<b>Edit Mode – Flashing Cursor</b> to edit = zone number then [*], then zone number again 6 = save word and go to next word in a descriptor 8 = save descriptor and go to next zone [#] = return to Program Alpha prompt (to quit)	Descriptor screen for zone 1 appears. To program a descriptor (up to 3 words) for a zone, do the following: 1. Enter the desired zone number (existing descriptor, if any, is displayed) and press [*], then enter the zone number again to start edit mode (flashing cursor appears). 2. a. Press [#] plus the 3-digit number from the Alpha Vocabulary List for the first word. b. Press [6] to accept the word and move the cursor for the next word in the descriptor. 3. Repeat steps 2a and 2b for the second and third words (if used). 4. When all words for that descriptor have been entered, press [8] to save the descriptor for that zone. The summary screen displays for that zone and the flashing cursor disappears. 5. Press [*] at the summary screen and repeat steps 1-4 to assign a descriptor for the next zone. 6. When all descriptors have been entered, press [#] at the last descriptor summary screen to return to the PROGRAM ALPHA? prompt. Enter 0 (no) at the prompt to exit this mode and return to Data Field mode.

EXAMPLE:

(a)

\* ZN 01 [B]ACK

(b)

\* ZN 01 BACK  
[ ]

(c)

\* ZN 01 BACK  
[D]OOR

(d)

\* ZN 01 BACK  
DOOR [ ]

\* ZN 01 BACK  
DOOR

### Descriptor Example

EXAMPLE: "BACK DOOR"

- From the list, BACK = 013, so, after entering the zone number to be edited (step 1), enter #013. If you accidentally enter the wrong word, simply press [#] plus the correct 3-digit number for the word you want.
- Press [6] to accept the selected word and continue to the next word. (if this is the only word you are using for the descriptor press [8] to save it).
- Enter the 3-digit number for the next word, "DOOR," whose number is "057." Enter # 0 5 7.
- Because this is the last word in the example descriptor, press [8] to save it. (If there was a third word in the descriptor, press [6] to accept the selected word and continue to the third word.) The summary screen displays with the selected descriptor.

### Summary Screen

- [\*] = to enter another zone number
- [#] = return to Program Alpha prompt (to quit)

The flashing cursor disappears, indicating that the word(s) are saved for that zone, as shown in the summary display at the left. To enter a descriptor for the next zone, press [\*] plus the desired zone number. The summary display appears. Repeat the previous steps to enter the descriptor for the zone.

### Adding Custom Words (will not be annunciated by 4286 Phone Module)

You can add up to 10 installer-defined words to the built-in vocabulary, which can then be used when programming zone descriptors. Each of the 10 words can actually consist of a word string of one or more words, but no more than *ten* characters can be used for each word or word string.

When adding custom words, the keypad keys perform the following functions:

[4]	Moves cursor one space to the left.
[6]	Moves cursor one space to the right.
[8]	Saves the new word in the system's memory.

- Select Custom Word mode (enter 1) when the prompt "CUSTOM WORD ?" is displayed.
  - Enter the number (01-10†) of the custom word or word string to be created, corresponding to index numbers 245 - 254 respectively (for example, if you are creating the first custom word or word-string, enter 01, for the second, enter 02, etc.). A cursor will now appear at the beginning of the second line.  
† or 11, 12, 13 for partition 1, partition 2 and common lobby descriptors respectively. See Assigning Partition Descriptors paragraph below.
- NOTE:** Custom words 8, 9, and 10 are "reminder words" that are programmed using Scheduling Mode.
- Refer to the Character List of letters, numbers, and symbols on a following page. Press [#], followed by the two-digit entry for the first letter you would like to display (e.g., # 65 for "A"). Press [6] to advance the cursor to the right, in position for the next character.  
**To delete a character**, simply enter the SPACE character (#32) at the unwanted character's location..
  - Repeat Step 3 to create the desired word(s). Note that the "4" key can be used to move the cursor to the left, if necessary. Remember, no word or word-string can exceed 10 characters (except custom message/partition descriptor word numbers 11, 12, and 13, which can be a maximum of 16 characters).
  - When the word is complete, press the [8] key to save the custom word(s) and return to the "CUSTOM WORD ?" display. Repeat Steps 2-5 for other custom words to be entered. To change a custom word, just overwrite it. When all words have been programmed, press [0] to return to the Descriptor entry. The custom word(s) will be automatically added to the built-in vocabulary.

### Assigning Partition/Custom Message Descriptors

VISTA-15P: You can create a custom message display that appears on alpha keypads instead of "System Ready." To assign a custom message, use word number 11 as described below.

VISTA-20P: You can assign a partition descriptor (up to 16 characters) for each partition plus the common lobby. The system displays the appropriate partition's word instead of "DISARMED READY TO ARM."

Use the same procedure as for adding custom words (described above), but use these word numbers in step 2:

- 11 = partition 1 \_\_\_\_\_
- 12 = partition 2 \_\_\_\_\_ (VISTA-20P only)
- 13 = common lobby \_\_\_\_\_ (VISTA-20P only)

Once a custom word is entered in any of these word locations (11-13), the system displays the appropriate partition's word instead of the default "DISARMED READY TO ARM" message.

# ALPHA VOCABULARY LIST (For Entering Zone Descriptors)

000 (Word Space)	• 057 <b>DOOR *</b>	- L -	- R -	- V -
• 001 <b>AIR</b>	• 059 <b>DOWN</b>	• 106 <b>LAUNDRY *</b>	155 RADIO	209 VALVE
• 002 <b>ALARM *</b>	• 060 <b>DOWNSTAIRS</b>	• 107 <b>LEFT</b>	• 156 <b>REAR</b>	210 VAULT
004 ALLEY	061 DRAWER	108 LEVEL	157 RECREATION	212 VOLTAGE
005 AMBUSH	• 062 <b>DRIVEWAY</b>	• 109 <b>LIBRARY *</b>	159 REFRIGERATION	- W -
• 006 <b>AREA</b>	• 064 <b>DUCT</b>	• 110 <b>LIGHT</b>	160 RF	213 WALL
• 007 <b>APARTMENT</b>	- E -	111 LINE	• 161 <b>RIGHT</b>	214 WAREHOUSE
• 009 <b>ATTIC *</b>	• 065 <b>EAST</b>	• 113 <b>LIVING *</b>	• 162 <b>ROOM *</b>	• 216 <b>WEST</b>
010 AUDIO	066 ELECTRIC	• 114 <b>LOADING</b>	163 ROOF	• 217 <b>WINDOW *</b>
- B -	067 <b>EMERGENCY *</b>	115 LOCK	- S -	• 219 <b>WING</b>
• 012 <b>BABY *</b>	068 ENTRY	116 LOOP	164 SAFE	220 WIRELESS
• 013 <b>BACK *</b>	• 069 <b>EQUIPMENT</b>	117 LOW	165 SCREEN	- X -
• 014 <b>BAR</b>	• 071 <b>EXIT *</b>	• 118 <b>LOWER</b>	166 SENSOR	222 XMITTER
• 016 <b>BASEMENT *</b>	072 EXTERIOR	- M -	• 167 <b>SERVICE</b>	- Y -
• 017 <b>BATHROOM *</b>	- F -	• 119 <b>MACHINE</b>	• 168 <b>SHED *</b>	223 YARD
• 018 <b>BED</b>	• 073 <b>FACTORY</b>	121 MAIDS	169 SHOCK	- Z -
• 019 <b>BEDROOM *</b>	075 FAMILY	122 MAIN *	• 170 <b>SHOP *</b>	224 ZONE (No.)
020 BELL	• 076 <b>FATHERS</b>	• 123 <b>MASTER *</b>	171 SHORT	• 225 <b>ZONE *</b>
• 021 <b>BLOWER</b>	• 077 <b>FENCE</b>	• 125 <b>MEDICAL *</b>	• 173 <b>SIDE *</b>	• 226 <b>0</b>
• 022 <b>BOILER</b>	• 079 <b>FIRE *</b>	126 MEDICINE	174 SKYLIGHT	• 227 <b>1</b>
023 BOTTOM	• 080 <b>FLOOR *</b>	128 MONEY	175 <b>SLIDING *</b>	• 228 <b>1ST *</b>
025 BREAK	081 FLOW	129 MONITOR	• 176 <b>SMOKE *</b>	• 229 <b>2</b>
• 026 <b>BUILDING</b>	082 FOIL	• 130 <b>MOTHERS</b>	• 178 <b>SONS</b>	• 230 <b>2ND *</b>
- C -	• 083 <b>FOYER</b>	• 131 <b>MOTION *</b>	• 179 <b>SOUTH</b>	• 231 <b>3</b>
028 CABINET	084 FREEZER	132 MOTOR	180 SPRINKLER	• 232 <b>3RD *</b>
• 029 <b>CALL</b>	• 085 <b>FRONT *</b>	- N -	• 182 <b>STATION</b>	• 233 <b>4</b>
030 CAMERA	- G -	• 134 <b>NORTH</b>	184 STORE	• 234 <b>4TH</b>
031 CAR	• 089 <b>GARAGE *</b>	135 NURSERY	• 185 <b>STORAGE *</b>	• 235 <b>5</b>
033 CASH	• 090 <b>GAS</b>	- O -	186 STORY	• 236 <b>5TH</b>
034 CCTV	091 GATE	• 136 <b>OFFICE *</b>	190 <b>SUPERVISED *</b>	• 237 <b>6</b>
035 CEILING	• 092 <b>GLASS</b>	• 138 <b>OPEN *</b>	191 SUPERVISION	• 238 <b>6TH</b>
036 CELLAR	093 GUEST	139 OPENING	192 SWIMMING	• 239 <b>7</b>
• 037 <b>CENTRAL</b>	094 GUN	• 140 <b>OUTSIDE</b>	193 SWITCH	• 240 <b>7TH</b>
038 CIRCUIT	- H -	142 OVERHEAD	- T -	• 241 <b>8</b>
• 040 <b>CLOSED *</b>	• 095 <b>HALL *</b>	- P -	194 TAMPER	• 242 <b>8TH</b>
• 046 <b>COMPUTER</b>	• 096 <b>HEAT</b>	143 PAINTING	196 TELCO	• 243 <b>9</b>
047 CONTACT	098 HOLDUP	• 144 <b>PANIC *</b>	197 TELEPHONE	• 244 <b>9TH</b>
- D -	099 <b>HOUSE *</b>	145 PASSIVE	• 199 <b>TEMPERATURE</b>	245 Custom Word #1
• 048 <b>DAUGHTERS</b>	100 INFRARED	• 146 <b>PATIO *</b>	200 THERMOSTAT	246 Custom Word #2
049 DELAYED	• 101 <b>INSIDE *</b>	147 PERIMETER	• 201 <b>TOOL</b>	247 Custom Word #3
• 050 <b>DEN *</b>	102 INTERIOR	• 148 <b>PHONE</b>	202 TRANSMITTER	248 Custom Word #4
051 DESK	103 INTRUSION	150 POINT	- U -	249 Custom Word #5
• 052 <b>DETECTOR *</b>	- J -	151 <b>POLICE *</b>	• 205 <b>UP</b>	250 Custom Word #6
• 053 <b>DINING *</b>	104 JEWELRY	152 <b>POOL *</b>	• 206 <b>UPPER</b>	251 Custom Word #7
054 DISCRIMINATOR	- K -	• 153 <b>POWER</b>	• 207 <b>UPSTAIRS *</b>	252 Custom Word #8
055 DISPLAY	• 105 <b>KITCHEN *</b>		• 208 <b>UTILITY *</b>	253 Custom Word #9
				254 Custom Word #10

**Note:** Bulleted (•) words in **boldface type** are those that are also available for use by the 4286 Phone Module. If using a Phone module, and words other than these are selected for Alpha descriptors, the module will not provide announcement of those words.

*Italicized words followed by an asterisk indicate those words supported by the 6160V/6150V Voice Keypads*

## CHARACTER (ASCII) CHART (For Adding Custom Words)

32 (space)	41 )	50 2	59 ;	68 D	77 M	86 V
33 !	42 *	51 3	60 <	69 E	78 N	87 W
34 "	43 +	52 4	61 =	70 F	79 O	88 X
35 #	44 ,	53 5	62 >	71 G	80 P	89 Y
36 \$	45 -	54 6	63 ?	72 H	81 Q	90 Z
37 %	46 .	55 7	64 @	73 I	82 R	
38 &	47 /	56 8	65 A	74 J	83 S	
39 '	48 0	57 9	66 B	75 K	84 T	
40 (	49 1	58 :	67 C	76 L	85 U	

# SETTING SCHEDULES

(Installer Code + [#] + [6] [4])

The system provides schedules, which can be used to automatically control 11 types of system events at pre-defined times. Some events are reserved for the installer only.

VISTA-20P: Provides up to 32 schedules: 16 schedules for use by the end-user, 16 for use by the installer.

VISTA-15P: Provides up to 8 schedules: 4 schedules for use by the end user, 4 for use by the installer.

## NOTES:

- The master code can only access schedules 01-16 (VISTA-15P = 01-04) and events 00-07.
- System clock must be set before schedules can take effect.
- Programmed schedules do not take effect until the next scheduled “start” time. (e.g., if programming a schedule time window for 8AM to 5PM, the schedule does not take effect until 8AM after the schedule has been programmed.)

## Schedule Mode

<div style="border: 1px solid black; padding: 2px;"> ENTER SCHED NO.  00=QUIT      00 </div>	<b>Schedule Number</b> VISTA-20P 01-16 = end-user schedules 17-32 = installer-only VISTA-15P 01-04 = end-user schedules 05-08 = installer-only [*] to continue	Enter the desired schedule number. <b>To Quit</b> , enter 00.
<div style="border: 1px solid black; padding: 2px;"> ENTER EVENT </div>	<b>Enter Event</b> 00 = clear event 01 = Relay On/Off 02 = User Access 03 = Latch Key Report to Pager 04 = Forced Stay Arming† 05 = Forced Away Arming† 06 = Auto Disarm 07 = Display “Reminder” 10 = Display custom words †† 11 = Periodic Test Report†††  Press [*] to continue.	Enter the desired event number for event you want to occur at a specified time. Events 10-11 are reserved for the installer only.  Latch key report (option 03) is sent to all pagers in the user’s partition and is active only when the system is armed (message sent is 777-7777). User must be enabled for paging (see User Attributes in <b>System Operation</b> section).  † Forced bypass is automatically enabled regardless of setting in field *23. †† If selected, system displays custom words 8, 9, and 10 at defined time. Can be used as installer’s reminder message to the end user. ††† See key commands in Test Report Code data field *64 section to quickly set periodic test reporting intervals.
<div style="border: 1px solid black; padding: 2px;"> DEVICE NUMBER                    XX </div>	<b>Device Number</b> V20P: 01-18 = device number V15P: 01-08, 17, 18 Press [*] to continue.	(For event 01-relay on/off) Enter the physical device number as programmed in *79 Menu Mode, then press [*] to continue to the “Start” prompt. Device numbers 17 and 18 designate built-in triggers 1 and 2 respectively.
<div style="border: 1px solid black; padding: 2px;"> GROUP NUMBER                    X </div>	<b>Group Number</b> 1-8 = group number Press [*] to continue to the “Start” prompt.	(For event 02-user access)
<div style="border: 1px solid black; padding: 2px;"> PARTITION                    X </div>	<b>Partition</b> 0 = all partitions 1 = partition 1 2 = partition 2 3 = common Press [*] to continue to the “Start” prompt.	(V20P only; for events 03-07, 10)
<div style="border: 1px solid black; padding: 2px;"> START   SMTWTFS  HH MMAM 0010000 </div>	<b>Start Time</b> 01-12 = hour 00-59 = minute 0 = AM; 1 = PM Days = place “1” under days Press [*] to continue.	Enter the event’s start time and days of the week to occur. To select days, position the cursor under the desired days using the [*] key to move forward, then press “1” to select the day.
<div style="border: 1px solid black; padding: 2px;"> STOP    SMTWTFS  HH MMAM 0010000 </div>	<b>Stop Time</b> 01-12 = hour 00-59 = minute 0 = AM; 1 = PM Days = place “1” under days Press [*] to continue.	(For events 01-relay on/off; 02-user access; 03-latch key report) Enter the event’s stop time and days of the week to occur. To select days, position the cursor under the desired days using the [*] key to move forward, then press “1” to select the day.



REPEAT OPTION	
0-4	X

**Repeat Option**  
 0 = do not repeat  
 1 = repeat weekly  
 2 = repeat biweekly (every other week)  
 3 = repeat every third week  
 4 = repeat every fourth week  
 Press [\*] to continue.

Enter the desired repeat option for this schedule.  
 e.g., To make a schedule that happens everyday you would select all days with a repeat count of 1. To make a schedule that runs for one week then stops, select everyday with a repeat count of 0.

RANDOMIZE		
0=NO	1=YES	X

**Randomize**  
 0 = no  
 1 = yes  
 Press [\*] to continue and return to ENTER SCHED NO. prompt to program the next schedule.

(For events 01 and 11)  
 If selected, the scheduled start and stop times will vary within 60 minutes of the "hour" time. For example, if a schedule is set to start at 6:15pm, it will do so the first time 6:15pm arrives, but on subsequent days it will start anytime between 6:00 and 6:59 p.m.

**NOTE:** Do not use the random option if the start and stop times are within the same "hour" setting, otherwise unpredictable results may occur (e.g., the randomized stop time may occur before the start time).

## AVS SYSTEM ENABLE and QUICK PROGRAMMING COMMANDS

Applies to an AVS system using an ECP connection to the control.

1. Install the AVS module according to its instructions.
2. Use one of the control's AVS Quick Program commands as follows (see Quick Program Command Results below for results of each command):
  - **installer code + [#] + [0] + 3:** enable AVS operation without panel sounds on the AVST speaker
  - **installer code + [#] + [0] + 4:** enable AVS operation and enable panel sounds on the AVST speaker
3. Use data field \*55 Dynamic Signaling Priority to select the desired reporting paths (phone line and/or GSMV4G, GSMX4G) and path for AAV communication.
4. To undo the Quick Command programming, use the following commands:
  - **installer code + [#] + [0] + 5:** remove all options set by [#] + [0] + 3 quick command
  - **installer code + [#] + [0] + 6:** remove all options set by [#] + [0] + 4 quick command

### Quick Program Command Results

When either the #03 or #04 Quick Program command is used, the following are automatically programmed and no longer available for other control panel purposes.

Pre-Programmed	#03 Command		#04 Command	
Output Function No. (*80 mode)	<b>VISTA-15P series</b> 22 (zone type 60, relay 07) 23 (zone type 61, relay 08) 24 (zone type 62, relay 08)	<b>VISTA-20P series</b> 46 (zone type 60, relay 15) 47 (zone type 61, relay 16) 48 (zone type 62, relay 16)	<b>VISTA-15P series</b> Same as #03 plus: 17 (zone type 14, relay 05) 18 (zone type 22, relay 05) 19 (zone type 39, relay 06) 20 (zone type 33, relay 06) 21 (zone type 36, relay 06)	<b>VISTA-20P series</b> Same as #03 plus: 41 (zone type 14, relay 13) 42 (zone type 22, relay 13) 43 (zone type 39, relay 14) 44 (zone type 33, relay 14) 45 (zone type 36, relay 14)
Output Relay No. (*79 mode)	07 (addr 08, relay pos 2) 08 (addr 08, relay pos 1)	15 (addr 11, relay pos 2) 16 (addr 11, relay pos 1)	Same as #03 plus: 05 (addr 08, relay pos 4) 06 (addr 08, relay pos 3)	Same as #03 plus: 13 (addr 11, relay pos 4) 14 (addr 11, relay pos 3)
Protection Zone (*56/*58 mode)	4229 zn 24 (zt 81, addr 08)	4229 zn 48 (zt 81, addr 11)	Same as #03 command	Same as #03 command
Device Address	address 08 (AVS module)	address 11 (AVS module)	Same as #03 command	Same as #03 command
Data Field *91	AAV enabled	AAV enabled	AAV enabled	AAV enabled

## SETTING THE REAL-TIME CLOCK

**IMPORTANT:** The Real-Time Clock must be set before the end of the installation.

**NOTE:** All partitions must be disarmed before the date/time can be set.

1. Master Code + [#] + [6] [3]
2. Press [\*] when the time/date is displayed.  
 A cursor appears under the first digit of the hour.  
*To move cursor ahead, press [\*]. To go back, press [#].*
  - Enter the 2-digit hour setting.
  - Enter the 2-digit minute setting.
  - Press [1] for PM or [2] for AM.
  - Enter the last two digits of the current year.
  - Enter the 2-digit month setting.
  - Enter the 2-digit day setting.
3. To exit, press [\*] when cursor is at the last digit, or wait 30 seconds.

## \*29 COMMUNICATION DEVICE MENU MODE (Pass-Through Programming)

This mode is for programming an IP, GSM, or IP/GSM Communicator Module using an alpha keypad. Alternatively, these options can be programmed via the AlarmNet Direct website. After programming is complete, the module must be registered with AlarmNet before reporting via the communication device can occur. Refer to the device's instructions for registration procedures.

**NOTE:** The module must be set to device address 3.

**IMPORTANT:** The use of an IP/GSM Communicator Module requires an AlarmNet-I account. Please obtain the account information from the central station prior to programming this module.

### Using an Alpha Keypad as a 7720P Programming Tool

When programming with \*29 menu mode, the alpha keypad mimics the functions of the 7720P Programming Tool. See figure to right and table below for 7720P key functions. Each key has two possible functions: a normal function and a SHIFT function.

**Normal functions:** The numeric values labeled directly on the keys and the left-hand functions shown in diagram on the ABC keys. To perform a normal key function, simply press the desired key.

**SHIFT functions:** Those functions shown in diagram above the numerical keys and the right-hand functions shown on the ABC keys. To perform a SHIFT key function, press SHIFT key (D key), then press the desired function key (shift function is indicated by the lit READY LED).

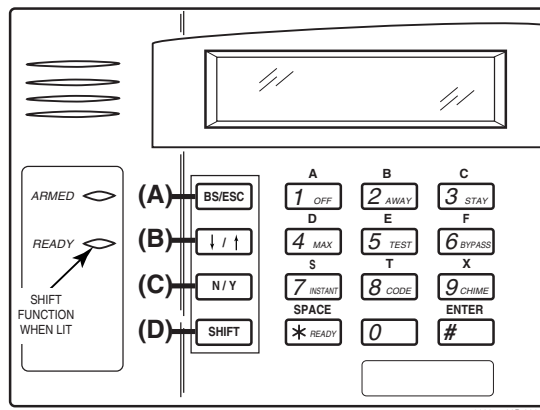

7720P Emulation Template for Alpha Keypads

### \*29 IP/GSM Program Mode

Press \*29 while in Data Field Programming mode. The following prompts appear.

ENABLE IP/GSM?  
0=No, 1=Yes

**Enable IP/GSM?**  
0 = no, not using IP or GSM;  
1 = yes using IP and/or  
GSM module  
[\*] to continue  
[Default = 0 (no IP and/or GSM)]

If using a communication device, enter 1 at this prompt and enter 1-Prog at the next prompt to program the device. Use the communication device's Installation Guide for details of the device's programming prompts and instructions for registration.

**Fixed-Word Keypad Note:** Although programming IP/GSM options cannot be done via a fixed-word keypad, IP/GSM can be enabled by doing the following:

Enter \*29 (to enter IP/GSM menu mode), then press 1 + [\*] + [\*]

1=PROG 2=DIAG  
0=QUIT

**Programming /  
Diagnostics Select**  
1 = Prog (program the  
IP/GSM options)  
2 = Diag (diagnostic mode)  
0 = Quit; returns to data field  
programming mode

Select whether you want to program the communication device or enter the device's diagnostic mode.

**Diagnostic Mode Note:** Diagnostic mode option available only for communicators with firmware version 2.4.16 or higher.

### Normal and SHIFT key Functions While in \*29 Menu Mode

Key	Normal Key Function	SHIFT Key Function
(A) = BS/ESC	[BS]: Press to delete entry Also, can reset EEPROM defaults †	[ESC]: Press to quit Program Mode
(B) = ↓/↑	[↓]: Scroll down programming	[↑]: Scroll up programming
(C) = N/Y	[N]: Press for "NO" answer	[Y]: Press SHIFT-Y for "YES" answer
(D) = SHIFT	Press before pressing a SHIFT key function. Will light READY LED. LED goes out once a key is pressed. Press again for each SHIFT function desired.	
1/A	[1]: For entering the number 1	[A]: Used for entering C.S. ID number
2/B	[2]: For entering the number 2	[B]: Used for entering C.S. ID number
3/C	[3]: For entering the number 3	[C]: Used for entering C.S. ID number
4/D	[4]: For entering the number 4	[D]: Used for entering C.S. ID number
5/E	[5]: For entering the number 5	[E]: Used for entering C.S. ID number
6/F	[6]: For entering the number 6	[F]: Used for entering C.S. ID number
7/S	[7]: For entering the number 7	[S]: Press to display diagnostic status
8/T	[8]: For entering the number 8	[T]: Press to send TEST messages
9/X	[9]: For entering the number 9	[X]: Press to reset the IP/GSM
[*] / SPACE	[*]: Used to select programming options	[SPACE]: Not used
0	[0]: For entering the number 0	
[#] / ENTER	[#] / ENTER: Press to accept entries	No SHIFT function

† Active only when the "REVIEW?" prompt is displayed

## Registering the Communication Device with AlarmNet

The communication device must be registered with AlarmNet before internet communication (via IP or GSM) can occur.

### Register Using the Alpha Keypad and \*29 Menu Mode

1. Enter \*29 Menu mode, select Diagnostic mode, then press Shift then [↑] key (D key followed by the B key). The registration message is sent (“Registering” displayed) and the control waits for the acknowledgment.
2. “Registration SUCCESS” displayed, indicating successful registration.

### Or Register with AlarmNet Direct Website or by Phone

To register via AlarmNet Direct Website, please go to: <https://services.alarmnet.com/AlarmNetDirect/userlogin.aspx>.

To register by phone, call 1-800-222-6525. You will need the MAC ID and MAC CRC number and Subscriber information.

## Communication Device Status Report Codes

The Communication Device sends status messages to the control panel for network connectivity failures. Trouble messages are displayed on the keypad as “Check 103,” with status displayed as “LngRng Radio” followed by a 4-digit keypad display status code, defined below.

### Keypad Display Status Codes

CODE	DESCRIPTION
0000	Control panel lost communication with internal device
0005	Communication device has lost contact with AlarmNet-G network
000F	Communication device is not registered; account not activated
0019	GSM module shut down
0400	Communication device Power-on reset

## UPLOADING/DOWNLOADING VIA the INTERNET

**UL:** Up/downloading via the Internet has not been evaluated by UL.

This control, when used with a compatible Internet/Intranet Communication Device, supports upload/download programming capability via the Internet using the AlarmNet network or, depending on the communication module used, a Private local area network (Intranet). This allows site maintenance independent of central station monitoring, and modification to sites globally via the Internet. Depending on the module used, Internet connection from the protected premises is either via high speed (broadband) cable or phone service, or via the GSM/GPRS digital cellular network (GSM modules).

Refer to the instructions provided with the communication module for information regarding its installation, programming, and registration. The System Requirements table below lists two sets of system requirements, depending upon whether you intend to communicate over the Internet or whether you are communicating over a Private LAN (Intranet).

**Compatible Communication Modules:** The following modules support Internet uploading/downloading, but future modules may also provide Internet upload/download support; refer to the module’s instructions for compatibility. Compatible Modules: 7845i-ent (supports LAN), GSMV4G, GSMX4G, IGSMV4G

### System Requirements

Internet Communication	Intranet (Private LAN) Communication, if applicable*
<p>At the Installation Site:</p> <ul style="list-style-type: none"><li>• Appropriate Internet Communication Module</li><li>• 7720P Programmer</li><li>• Broadband Internet Access (for wired modules)</li><li>• Broadband (Cable/DSL) Modem (for wired modules)</li><li>• Broadband (Cable/DSL) Router (for wired modules if connecting more than one device to the Internet)</li><li>• IP compatible Control Panel</li></ul> <p>At the Downloading Office:</p> <ul style="list-style-type: none"><li>• Broadband Internet Access</li><li>• Broadband (Cable/DSL) Modem</li><li>• Broadband (Cable/DSL) Router (optional, if connecting more than one device to the Internet)</li><li>• Computer running Compass Downloading Software version that supports Internet upload/download for this control.</li></ul>	<p>At the Installation Site:</p> <ul style="list-style-type: none"><li>• Internet/Intranet Communication Module</li><li>• 7720P Programmer</li><li>• Ethernet Network Connection</li><li>• IP compatible Control Panel</li></ul> <p>At the Downloading Office:</p> <ul style="list-style-type: none"><li>• 7810iR-ent IP Receiver and Internal Router</li><li>• Computer(s) running the following software:<ul style="list-style-type: none"><li>- Compass Downloading Software version that supports IP upload/download for this control.</li><li>- Compass Connect Data Server Application</li><li>- Compass Connect Control Server Application</li></ul></li></ul> <p>* see module’s instructions for applicability for LAN usage</p> <p><b>NOTE:</b> Compass, the Compass Connect Data Server, and the Compass Connect Control Server applications may all be installed on the same computer if desired. If they are installed on one computer, the computer must have a fixed IP Address.</p>

### To set up the control panel, do the following:

1. Connect the communication device to the control panel’s ECP (keypad) terminals.
2. Internet Users: Connect the communication device to the Internet via a cable/DSL modem and router.  
Intranet Users: Connect the communication device to the Intranet (LAN) via the appropriate Ethernet connection.
3. Enable the communication device (using \*29 Menu mode) to enable alarm reporting and module supervision.
4. Using the communication device’s programming menus (via \*29 Menu mode or 7720P programmer), program the communication device for address 3 and program the device’s other options as required.
5. Register the communication device with AlarmNet. The communication device must be registered before downloading or alarm reporting can take place.

### To perform upload/download functions:

1. Connect the computer to the Internet and start the Compass downloading software.
2. Open the control’s account, then select the Communications function and click the Connect button.
3. At the Connect screen, check that the control’s MAC address is entered and the TCP/IP checkbox is checked.
4. Click Connect. The Internet connection to the control is made automatically via AlarmNet.
5. Once connected, use the Compass downloading software as normal to perform upload/download functions.

## ZONE TYPE DEFINITIONS

Zone types define the way in which the system responds to faults in each zone.

### Type 00 Zone Not Used

Program a zone with this zone type if the zone is not used.

### Type 01 Entry/Exit Burglary #1

- Assign to zones that are used for primary entry and exit.
- Provides entry delay when zone is faulted if control is armed in the Away, Stay, or Night-Stay modes.
- No entry delay provided when the panel is armed in the Instant/Maximum mode.
- Entry delay #1 is programmable for each partition (field \*35).
- Exit delay begins whenever the control is armed, regardless of the arming mode selected, and is programmable (field \*34).

### Type 02 Entry/Exit Burglary #2

- Assign to zones that are used for entry and exit and require more time than the primary entry/exit point.
- Provides a secondary entry delay, similar to entry delay #1.
- Entry delay #2 is programmable for each partition (field \*36).
- Exit delay is same as described for Type 01.

### Type 03 Perimeter Burglary

- Assign to all sensors or contacts on exterior doors and windows.
- Provides an instant alarm if the zone is faulted when the panel is armed in the Away, Stay, Night-Stay, Instant or Maximum modes.

### Type 04 Interior Follower

- Assign to a zone covering an area such as a foyer, lobby, or hallway through which one must pass upon entry (to and from the keypad).
- Provides a delayed alarm (using the programmed entry 1 time) if the entry/exit zone is faulted first. Otherwise this zone type gives an instant alarm.
- Active when the panel is armed in the Away mode.
- Bypassed automatically when the panel is armed in the Stay or Instant modes; if armed in Night-Stay mode, zones assigned to zone list 05 (night-stay zone list) are not bypassed when system armed in Night-Stay mode.

### Type 05 Trouble by Day/Alarm by Night

- Assign to a zone that contains a foil-protected door or window (such as in a store), or to a zone covering a sensitive area such as a stock room, drug supply room, etc.
- Can also be used on a sensor or contact in an area where immediate notification of an entry is desired.
- Provides an instant alarm if faulted when armed in the Away, Stay, Night-Stay, Instant or Maximum (night) modes.
- During the disarmed state (day), the system will provide a latched trouble sounding from the keypad (and a central station report, if desired).

### Type 06 24-hr Silent Alarm

- Usually assigned to a zone containing an emergency button.
- Sends a report to the central station but provides no keypad display or sounding.

### Type 07 24-hour Audible Alarm

- Assign to a zone that has an emergency button.
- Sends a report to the central station, and provides an alarm sound at the keypad, and an audible external alarm.

### Type 08 24-hour Auxiliary Alarm

- Assign to a zone containing an emergency button, or to a zone containing monitoring devices such as water or temperature sensors.
- Sends a report to the central station and provides an alarm sound at the keypad. (No bell output.)

### Type 09 Supervised Fire

- Provides a fire alarm on short circuit and a trouble condition on open circuit. A fire alarm produces a pulsing bell output.
- This zone type is always active and cannot be bypassed.

### Type 10 Interior w/Delay

- Provides entry delay (using the programmed entry time), if tripped when the panel is armed in the Away mode.
- Entry Delay 1 begins whenever sensors in this zone are violated, regardless of whether or not an entry/exit delay zone was tripped first.
- Bypassed when the panel is armed in the Stay or Instant modes; if armed in Night-Stay mode, zones assigned to zone list 05 (night-stay zone list) are not bypassed when system armed in Night-Stay mode.

### Type 12 Monitor Zone

- Works as a dynamic monitor of a zone fault/trouble (not alarm). In the case of a short/open, the message, "\*\*ALARM\*-24 Hr. Non-Burg. -#XXX " (where XXX is the zone number) will be sent to the Central Station. The system keypad will display a "check" message indicating the appropriate zone (but keypad beeping does not occur). Upon restoral of the zone, the message, "\*\*RESTORE\*-24 Hr. Non-Burg. -#XXX " will be sent to the Central Station.
- The "check" message will automatically disappear from the keypad dynamically, when the zone restores; a user code + off sequence is not needed to reset the zone.
- Faults of this zone type are independent of the system, and can exist at the time of arming without interference.
- Since this is a "trouble" zone type, do not use this zone type with relays set to activate upon "alarm."

### Type 14 24 Hour Carbon Monoxide Monitor

- Assigned to any zone with a carbon monoxide detector.
- A carbon monoxide alarm produces keypad and detector sounding (does not affect bell output).
- Always active and cannot be bypassed.

### Type 16 Fire w/Verification

- Provides a fire alarm when zone is shorted, but only after the alarm is verified to help eliminate false alarms due to electrical or physical transients.
- Verifies alarm by resetting smoke detectors after short is detected (removes power 7 seconds for zone 1, 3 seconds for trigger output). Another short circuit within 90 seconds triggers fire alarm, otherwise first alarm is ignored.
- Provides a trouble response when zone is open.

### Type 20 Arm-Stay (BR only)

- Arms the system in Stay mode when the zone is activated.
- Pushbutton units send the user number to the central station when arming or disarming.
- User number for button must be assigned.

### Type 21 Arm-Away (BR only)

- Arms the system in Away mode when the zone is activated.
- Pushbutton units send the user number to the central station when arming or disarming.
- User number for button must be assigned.

### Type 22 Disarm (BR only)

- Disarms the system when the zone is activated.
- User number for button must be assigned.

### Type 23 \* No Alarm Response

- Can be used on a zone when an output relay action is desired, but with no accompanying alarm (e.g., lobby door access).

### Type 24 Silent Burglary

- Usually assigned to all sensors or contacts on exterior doors and windows where bells and/or sirens are NOT desired.
- Provides an instant alarm, with NO audible indication at any keypad or external sounder, if the zone is faulted when the system is armed in the Away, Stay, Instant, or Maximum modes.
- A report is sent to the central station.

### Type 77 Keyswitch

- Assign to zone wired to a keyswitch.
- Do not use input type "BR" devices with this zone type.

### Type 81 AAV Monitor Zone (for AVS)

- Assign to zone connected to AVS module.
- Monitors 2-way voice sessions as follows:
  - When the zone is faulted, all alarm sounding and dialer reporting stops, except for fire alarms, which immediately terminate the voice session and cause a fire report to be sent.
  - When the zone is restored (session ended), sounding resumes (if bell timeout has not expired) and reports that were stopped are sent.

### Types 90-93 Configurable

Allows for various custom responses. Options include response to entry/exit delays, response opens/shorts, types of alarm/trouble sounding, dial delay, and unique Contact ID report codes. Types 92 and 93 can only be programmed via downloader. UL installations: Zone Types 90 -93 may not be used as fire or burglar alarm zones on fire or UL burglar alarm installations.

- \* The system can still be armed when these zone types are in a faulted condition.

## REPORT CODE FORMATS

The following table describes the communication formats.

FORMAT TYPE	DESCRIPTION
3+1 and 4+1 Standard Formats Ex. <b>SSS(S) A</b>	Comprises a 3- (or 4-) digit subscriber number and a single-digit report code (e.g., Alarm, Trouble, Restore, Open, Close, etc). Ex. S = Subscriber ID; A = Report Code
3+1 and 4+1 Expanded Formats Ex. <b>SSS(S) A AAA(A) Z</b>	Comprises a 3- (or 4-) digit subscriber number and a two-digit report code. The first digit is displayed on the first line. The first digit is repeated on the second line 3 (or 4) times followed by the second, "expanded" digit. Ex. S = Subscriber ID; A = Report Code-1st digit; Z = Typically Zone Number-2nd digit
4+2 Format Ex. <b>SSSS AZ</b>	Comprises a 4-digit subscriber number and 2-digit report code. Ex. S = Subscriber ID; A = Report Code; Z = Typically Zone Number)
ADEMCO Contact ID Reporting Format Ex. <b>CCCC Q EEE GG ZZ</b>	Comprises a 4- or 10-digit subscriber number (depending on format selected), 1-digit event qualifier ("new" or "restore"), 3-digit event code, and 3-digit zone number, user number, or system status number (see below for example explanation).

### ADEMCO Contact ID®

The ADEMCO Contact ID® Reporting Format comprises the following:

- 4-digit or 10-digit subscriber number (depending on format selected).
- 1-digit event qualifier ("new" or "restore").
- 3-digit event code.
- 2-digit Partition No.
- 3-digit zone number, user number, or system status number (see table below).

ADEMCO Contact ID® Reporting takes the following format: CCCC(CCCCC) Q EEE GG ZZ

where: CCCC(CCCCC) =Customer (subscriber) ID

- Q = Event qualifier, where: E = new event , and R = restore
- EEE = Event code (3 hexadecimal digits)
- GG = Partition Number (system messages show "00")
- ZZZ = Zone/contact ID number reporting the alarm, or user number for open/close reports. System status messages contain zeroes in the ZZZ location.

### TABLE OF CONTACT ID EVENT CODES

(Some event codes may not apply to certain control panels;  
for a complete list of event codes, refer to the central office receiver manual)

Code	Definition
110	Fire Alarm
121	Duress
122	Alarm, 24-hour Silent
123	Alarm, 24-hour Audible
131	Alarm, Perimeter
132	Alarm, Interior
134	Alarm, Entry/Exit
135	Alarm, Day/Night
143	Alarm, Expansion Module
145	ECP Module cover tamper
146	Silent Burglary
150	Alarm, 24-Hour Auxiliary/Monitor zone
162	Carbon Monoxide
301	AC Power
302	Low System Battery/Battery Test Fail
305	System Reset (Log only)
321	Bell/Siren Trouble
333	Trouble, Expansion Mod. Supervision
341	Trouble, ECP Cover Tamper
344	RF Receiver Jam
351	Telco Line Fault
353	Long Range Radio Trouble
354	Failure to Communicate (log only)
373	Fire Loop Trouble
374	Exit Error Alarm
380	Global Trouble, Trouble Day/Night
381	RF Sensor Supervision
382	Supervision Auxiliary Wire Zone

Code	Definition
383	RF Sensor Tamper
384	RF Sensor Low-battery
393	Clean Me
401	Disarmed, Armed AWAY, Armed MAXIMUM
403	Schedule Arm/Disarm AWAY
406	Cancel by User
407	Remote Arm/Disarm (Downloading)
408	Quick Arm AWAY
409	Keypad Arm/Disarm AWAY
441	Disarmed/Armed STAY/INSTANT, Quick-Arm STAY/INSTANT
442	Keypad Arm/Disarm STAY
455	Scheduled Arm Fail
459	Recent Closing (SIA panels only)
570	Bypass
601	Manually Triggered Dialer Test
602	Periodic Test
606	AAV to Follow
607	Walk Test Entered/Exited
623	Event Log 80% Full
625	Real-Time Clock was Changed (log only)
627	Program Mode Entry (log only)
628	Program Mode Exit (log only)
642	Latch Key (log only)
750 - 789	Reserved for Configurable Zone Type report codes (check with central station when using these codes)

## SYSTEM SECURITY CODES

The systems provides one Installer code, one System Master code, plus a set of other user codes intended for other users of the system. These codes can each be assigned one of 5 authority levels, which determine the functions each code can perform as listed in the table below.

VISTA-20P: Provides 48 security codes (plus Installer code), including one System Master code, two Partition Master codes, and 45 general user codes.

VISTA-15P: Provides 32 security codes (plus Installer code), including one System Master code and 31 general user codes.

**Authority Levels** (can be assigned to users 03-49 only; users 1 and 2 cannot be changed)

Level	User No.	Functions
Installer	01	(default=4112) perform all security functions except can disarm only if used to arm; can enter program mode; can change System Master code; cannot assign any other user codes NOTE: For security purposes, the factory default installer code should be changed.
System Master	02	(default 1234) only one system master code per system; can perform all security functions, add/delete users in either partition, change system master code, view event log, set system clock, program keypad macro, program scheduled events, activate output devices (triggers/relays)
Partition Master (default)	P1 = 03 P2 = 33	VISTA-20P. Same as Master, except add/delete users limited to assigned partition only, (these users can be assigned different authority levels, if desired; any user can be assigned the partition master authority level)
0-User	03-49 (V20P) 03-33 (V15P)	perform security functions (arm, disarm, etc.) only; cannot add/delete users, view event log, set system clock or program scheduled events
1-Arm Only	see "user"	arm system only
2-Guest	see "user"	can disarm the system only if it was used to arm the system
3-Duress	see "user"	performs security functions, but also silently sends a duress message to the central station; reports as duress code user number.
4-Partition Master	see "user"	VISTA-20P. See Partition Master paragraph above; used to assign other user numbers as partition masters

Refer to the user guide for detailed procedures on adding/deleting security codes and changing user attributes.

The following is a brief description of how to add user codes.

### Changing the System Master code:

Using Installer code: Installer code + [8] + 02 + new code

Using current System Master code: System Master code + [8] + 02 + new code + new code again

**Adding a User Code:** Master code + [8] + 2-digit user no. + user's code

**Deleting a User Code:** Master code + [8] + 2-digit user no. + [#] [0]

**Assigning Attributes:** Master code + [8] + 2-digit user no. + [#] [attribute no.] + value

Attributes:	Values
1 = Authority Level	0-4 (see Authority Level table above)
2 = Access Group	0-8 (0 = not assigned to a group)
3 = Active Partition(s) for this user;	1, 2, 3 (common) Enter partitions consecutively if more than one and press [#] to end the entries.
4 = RF Zone No.	Assigns user number to button type zone for arm/disarm ( <b>keyfob must be enrolled in system first</b> ; see <i>Wireless Key Templates</i> section).

**Deactivating a key fob:** You can deactivate the arming/disarming functions for a key fob (ex. if lost or stolen) by deleting the associated key fob user. See "Delete a User" above. Other key fob functions such as panic or device activation (if programmed) remain active. To fully remove the programming for a key fob, delete the zone(s) associated with the key fob functions.

### IMPORTANT SECURITY NOTICE

Please inform the User about the security importance of their key fob, and what to do if it is lost.

Explain that the key fob is similar to their keys or access card. If lost or stolen, another person can compromise their security system. They should immediately notify the Dealer/Installer of a lost or stolen key fob. The Dealer/Installer will then remove the key fob programming from the security system.

5 = Open/Close Paging      1 for yes, 0 for no

## KEYPAD FUNCTIONS

The following is a brief list of system commands. For detailed information concerning system functions, refer to the User's Manual. For Touch Screen style keypad users, refer to the separate Touch Screen keypad (AUI) User's Guide.

### Keypad Commands

Function	Description
Silence Burglary Alarms	Pressing any key will silence the keypad sounder for 10 seconds. Disarming the system (security code + OFF) silences both keypad and external sounders.
Silence Fire or Carbon Monoxide Alarms	Press the OFF [1] key to silence the keypad sounder and, for fire alarms, the external sounder.
Quick Arm	If enabled (field *21), you can press [#] in place of the system's security code, plus the desired arming key (Away, Stay, Instant, Maximum)
Single-Button arming	If programmed (*57 Function Key menu mode), lettered keys A-D can be used for arming, using options 3-AWAY, 4-STAY, 5-NIGHT-STAY, or 6-Step-Arming
Alarm Memory	When the system is disarmed, any zones that were in an alarm condition during the armed period will be displayed. To clear this display, simply repeat the disarm sequence (enter the security code and press the OFF key) again.
Arming Away	Enter code + AWAY [2] or simply press appropriate lettered key on the keypads. If the "Auto-Stay Arm" feature is enabled (field *84) and the entry/exit door <b>is not</b> opened and closed within the programmed exit delay time, the system will automatically arm in STAY mode if armed from a wired keypad (non-RF device). If the door <b>is</b> opened and closed within the exit delay period, the system arms in AWAY mode.
Arming Stay	Enter code + STAY [3] or simply press appropriate key on the keypads (see "Single-Button Arming" above). See "Arming Away" above for Auto-Stay arming feature.
Arming Night-Stay	Enter code + STAY [3] + STAY [3] or simply press appropriate key on the keypads (see "Single-Button Arming" above).
Arming Instant	Enter code + INSTANT [7].
Arming Maximum	Enter code + MAXIMUM [4] or simply press appropriate lettered key on the keypads (see "Single-Button Arming" above).
Disarming	Enter code + OFF [1]. If entry delay or an alarm is active, you do not need to press OFF.
Bypassing Zones	Enter code + BYPASS [6] + zone number(s).
Forced (Quick) Bypass	To automatically bypass all faulted zones, use the "Quick Bypass" method. Enter code + BYPASS + [#], then wait for all open zones to be displayed. Arm when display indicates "ZONE BYPASSED" and "READY TO ARM".
Chime Mode	Enter code + CHIME [9]. To turn chime off, enter code + CHIME again.
Activate Output Devices	[Security Code] + # + 7 + [2-digit Device #] activates (starts) that device. [Security Code] + # + 8 + [2-digit Device #] deactivates (stops) that device.

## COMPATIBLE DEVICES

2-Wire Smoke Detectors	
Detector Type	Model No.
Photoelectric w/heat sensor	System Sensor 2WT-B
Photoelectric	System Sensor 2W-B
Photoelectric	System Sensor 2151 w/B110LP base
Photoelectric	Napco FW-2S
Keypads	
Fixed-Word Keypad	6150
Alpha Keypad	6160
Voice Keypads	6150V, 6160V
Touch Screen Keypad	6272, 6280, TUXEDO
Wireless Receivers	
Up to 8 transmitters	5881L/5882L
Up to 16 transmitters	5881M/5882M
Up to system max transmitters	5881H/5882H
Transmitter Module	5800TM
Up to system max transmitters	5883
Keypad/Receivers	
Up to 16 trans, fixed-word	6150RF
Up to system max trans, alpha	6160RF
Modules	
Wired Expander Module	4219
Wired Expander/Relay Module	4229
Relay Module	4204
Phone Module	4286VIP
Communication Device	GSMV4G, GSMX4G, IGSMV4G etc.
Transformers	
25VA, 16.5VAC Plug-In Trans.	1321 (1321CN in Canada)
40VA, 16.5VAC Powerline Carrier Device Interface AC Transformer	1361X10

Sounders
AB12M 10" Motorized Bell & Box
1011BE12M 10" Motorized Bell & Box
702 Outdoor Siren
719 2-Channel Siren
713 High Power Speaker
746 Indoor Speaker
747 Indoor Siren
747PD Two-Tone Piezo Dynamic Indoor Siren
747UL Indoor Siren
748 Dual Tone Siren
749 Speaker/Horn
744 Siren Driver
745X3 Voice Siren Driver
705-820, 5-inch Round Speaker
713 Speaker
WAVE Speaker
WAVE2 Two-Tone Siren
WAVE2PD Two-Tone Piezo Dynamic Siren
5800WAVE Wireless Siren
System Sensor PA400B (beige); PA400R (red) Indoor Piezo Sounder

## VARIOUS SYSTEM TROUBLE DISPLAYS

Alpha Display	Fixed Disp.	Meaning
ALARM CANCELED	CA	Will appear if an exit or interior zone contained a fault during closing at the time the Exit Delay ended (e.g., exit door left open), but the system was disarmed during the Entry Delay time. The alarm sounder and keypad sound continuously, but stop when the system is disarmed. No message will be transmitted to the central station.
EXIT ALARM	EA	Appears when Exit Delay ends if an exit or interior zone contained a fault during closing. The alarm sounder and keypad sound continuously until the system is disarmed (or timeout occurs). An "Exit Alarm" message is sent to the central station. Also results if an alarm from an exit or interior zone occurs within 2 minutes after the end of an Exit Delay.
CHECK	CHECK	Indicates that a problem exists with the displayed zone(s) and requires attention.
ALARM 1xx FAULT 1xx CHECK 1xx	1xx 1xx 1xx 91	Indicates that communication between control and a zone expander or wireless receiver is interrupted, where "xx" is the device address. Check the wiring and DIP switch settings on the units. If field *199 is set to "1," all ECP module problems are displayed as "91." If there are wireless sensors in the system, the Check condition may also be caused by some change in the environment that prevents the receiver from receiving signals from a particular sensor.
SYSTEM LO BAT	BAT	With no zone number indicates that the system's standby battery is weak.
LO BAT	BAT	With a zone number and about twice-per-minute beeping at the keypad indicates that a low-battery condition exists in the wireless sensor displayed (zone "00" indicates a wireless keypad). If the battery is not replaced within 30 days, a "CHECK" display may occur. NOTE: Some wireless sensors contain a non-replaceable long-life battery which requires replacement of the entire unit at the end of battery life (e.g., Nos. 5802, 5802CP).
TELCO FAULT	94	Telephone Line Failure, indicates that a monitored telephone line (if programmed in field *92) has been cut or disconnected. Depending on how the system was programmed, the keypad may also produce a trouble sound, and the external sounder may be activated. Silence by entering installer code + OFF.
Busy-Standby	dl	If this remains displayed for more than 1 minute, the system is disabled. <b>NOTE for CANADIAN PANELS:</b> Power up time is 2 minutes, and CID code 305 System Reset is sent if the [#] + [0] command is not performed before the 2 minutes expires.
Modem Comm	CC	The system is in communication with the central station for change of function or status verification.
no display	no display	Power Failure If there is no keypad display at all and the LEDs are unlit, operating power (AC and battery) for the system has stopped and the system is inoperative. If the message "AC LOSS" (Alpha display keypads) or "NO AC" (Fixed-Word display keypads) is displayed, the keypad is operating on battery power only. If the battery standby capacity is used up during a prolonged AC power outage, the control's power will shut down to minimize deep discharge of the battery.
Comm. Failure	FC	A communication failure has occurred.
Open Circuit	0C	The keypad is not receiving signals from the control; sees an open circuit.
Long Rng Trbl	bF	Backup communication device (LRR) had communication failure.
Bell Failure	70	Bell supervision failure.
RCVR Jam	90	RF jam detected.
KEYPAD LOW BAT	00 BAT	Wireless keypad low battery.
Phone Okay	Cd	The dialer test has been successful (CID code 601).
Dialer Off	d0	The dialer is disabled.
Test in Progress	dd	Walk test mode is active (CID code 607).
Upload Completed	dC	The upload or download session was completed.
Upload Failed	dF	The upload or download session failed before completion.



## UL NOTICES

1. Entry Delay No. 1 and No. 2 (fields \*35, \*36) cannot be greater than 30 seconds for UL Residential Burglar Alarm installations, and entry delay plus dial delay should not exceed 1 minute. For UL Commercial Burglar Alarm installations, total entry delay may not exceed 45 seconds.
2. For UL Commercial Burglar Alarm and UL Residential Burglar Alarm installations with line security, total exit delay time must not exceed 60 seconds.
3. The maximum number of reports per armed period (field \*93) must be set to "0" (unlimited) for UL installations.
4. Periodic testing (see scheduling mode) must be at least every 24 hours.
5. Alarm Sounder plus Auxiliary Power currents must not exceed 600mA total for UL installations (Aux power 500mA max.).
6. All partitions must be owned and managed by the same person(s).
7. All partitions must be part of one building at one street address.
8. If used, the audible alarm device(s) must be placed where it/they can be heard by all partitions.
9. For UL commercial burglar alarm installations the control unit must be protected from unauthorized access. The tamper switch installed to protect the control unit enclosure door is suitable for this purpose.
10. Remote downloading without an alarm company technician on-site (unattended downloading) is not permissible for UL installations.
11. Auto-disarming is not a UL Listed feature.
12. As SIA limits for delay of alarm reporting and sounding can exceed UL limits for commercial and residential applications, the following UL requirements per UL681 are provided:  
The maximum time that a control unit shall be programmed to delay the transmission of a signal to a remote monitoring location, or to delay the energizing of a local alarm sounding device to permit the alarm system user to enter and disarm the system, or to arm the system and exit shall not exceed:
  - a) 60 seconds for a system with standard line security or encrypted line security,
  - b) 120 seconds for a system without standard line security or encrypted line security, or
  - c) 120 seconds for a system that does not transmit an alarm signal to a remote monitoring location.
13. This control is not intended for bank safe and vault applications.

## SIA QUICK REFERENCE GUIDE

1. \*31 Single Alarm Sounding per Zone: If "0" selected, "alarm sounding per zone" will be the same as the "number of reports in armed period" set in field \*93 (1 if one report, 2 if 2 reports, unlimited for zones in zone list 7).
2. \*34 Exit Delay: Minimum exit delay is 45 seconds.
3. \*35/\*36 Entry Delay 1 and 2: Minimum entry delay is 30 seconds.
4. \*37 Audible Exit Warning: Feature always enabled; field does not exist.
5. \*39 Power Up in Previous State: Must be "1," power up in previous state.
6. \*40 PABX Access Code or Call Waiting Disable: If call waiting is used, call waiting disable option in field \*91 must be set.
7. \*50 Burglary Dial Delay: Delay must be minimum of 30 seconds.
8. \*59 Exit Error Alarm Report Code: Always enabled.
9. \*68 Cancel Report Code: Default is "code enabled."
10. \*69 Recent Closing Report Code: Always enabled.
11. \*91 Option Selection: Exit Delay option should be enabled. If call waiting is used, Call Waiting Disable must be set to "1" (enabled).
12. \*93 No. reports in Armed Period: Must be set for 1 or 2 report pairs.
13. Cross zone timer programming is set in field \*85; cross zone pairs are assigned in zone list 4 using \*81 Zone List mode.
14. Duress code is assigned by using the "add a user code" procedure found in the User Guide. Enable Duress code reporting by programming zone 92 using \*56 Zone Programming mode.
15. Fire alarm verification is a built-in system feature when a zone is programmed for zone type 16.

## ULC S304 REQUIREMENTS (for VISTA-15PCN and VISTA-20PCN)

Refer to the following notes for systems intended for Low Risk Level (low extent of protection) and Medium Risk Level (medium extent of protection) installations.

### Low Risk Level

If the panel is used for Low Risk Level installations, the system must include the following:

- Subscriber control unit may use one telephone number, but it must be programmed that
  - a) it transmits over the single channel to the receiver once every 24 hour;
  - b) it detects a loss of communication and initiates the local trouble signal within 180 seconds;
  - c) in event of failure in the communication channel, all alarm and trouble signals must be annunciated locally.
- Protection circuit conductors shall form one fully supervised circuit so arranged that an alarm signal will be initiated at the central station from the effect of loss data, an open circuit or other change in normal status.
- Trouble response time must be in compliance with CAN/ULC-S301, Central and Monitoring Station Burglar Alarm Systems

### Medium Risk Level

If the panel is used for Medium Risk Level installations, the system must include the following:

- Subscriber control unit may use at least two communication levels, one being the telephone number and the other being a radio frequency communication channel – the GSM communicator may be used. The Subscriber control unit must be programmed that
  - a) it transmits over the both channels to the receiver once every 24 hours;
  - b) failure of communication of either channel is reported to the Central Station on the other channel within 240 sec;
  - c) the first attempt to send a status change signal shall utilize the Telephone line. Where it is known to have failed, transmission attempts over the alternate communication channel shall occur.
- Protection circuit conductors shall form double fully supervised circuits so arranged that an alarm signal will be initiated at the central station from the effect of loss data, an open circuit or other change in normal status.
- Trouble response time must be in compliance with CAN/ULC-S301, Central and Monitoring Station Burglar Alarm Systems

### Perimeter, Space, Safe, and Vaults Protection

Protection for perimeter, space, safe, and vaults need to be provided during the installation.

- For the Low Risk Security Level – Accessible openings should be contacted whether fixed or moveable;
- For the Medium Risk Security Level – All moveable and fixed accessible openings should be contacted.

## FCC STATEMENTS

### FEDERAL COMMUNICATIONS COMMISSION (FCC) Part 15

The user shall not make any changes or modifications to the equipment unless authorized by the Installation Instructions or User's Manual. Unauthorized changes or modifications could void the user's authority to operate the equipment.

### CLASS B DIGITAL DEVICE STATEMENT

This equipment has been tested to FCC requirements and has been found acceptable for use. The FCC requires the following statement for your information:

This equipment generates and uses radio frequency energy and if not installed and used properly, that is, in strict accordance with the manufacturer's instructions, may cause interference to radio and television reception. It has been type tested and found to comply with the limits for a Class B computing device in accordance with the specifications in Part 15 of FCC Rules, which are designed to provide reasonable protection against such interference in a residential installation. However, there is no guarantee that interference will not occur in a particular installation. If this equipment does cause interference to radio or television reception, which can be determined by turning the equipment off and on, the user is encouraged to try to correct the interference by one or more of the following measures:

- If using an indoor antenna, have a quality outdoor antenna installed.
- Reorient the receiving antenna until interference is reduced or eliminated.
- Move the radio or television receiver away from the receiver/control.
- Move the antenna leads away from any wire runs to the receiver/control.
- Plug the receiver/control into a different outlet so that it and the radio or television receiver are on different branch circuits.
- Consult the dealer or an experienced radio/TV technician for help.

This Class B digital apparatus complies with Canadian ICES-003.

Cet appareil numérique de la classe B est conforme à la norme NMB-003 du Canada.

### FCC/IC STATEMENT

This device complies with Part 15 of the FCC rules and RSS 210 of Industry Canada. Operation is subject to the following two conditions: (1) This device may not cause harmful interference, and (2) This device must accept any interference received, including interference that may cause undesired operation.

Cet appareil est conforme à la partie 15 des règles de la FCC & de RSS 210 des Industries Canada. Son fonctionnement est soumis aux conditions suivantes: (1) Cet appareil ne doit pas causer d'interférences nuisibles. (2) Cet appareil doit accepter toute interférence reçue y compris les interférences causant une réception indésirable.

## TELEPHONE/MODEM INTERFACE

### FCC Part 68

This equipment complies with Part 68 of the FCC rules. On the front cover of this equipment is a label that contains the FCC registration number and Ringer Equivalence Number (REN). You must provide this information to the telephone company when requested.

This equipment uses the following USOC jack: RJ31X

This equipment may not be used on telephone-company-provided coin service. Connection to party lines is subject to state tariffs. This equipment is hearing-aid compatible.

### Industry Canada

**NOTICE:** The Industry Canada Label identifies certified equipment. This certification means that the equipment meets telecommunications network protective, operational and safety requirements as prescribed in the appropriate Terminal Equipment Technical Requirements document(s). The Department does not guarantee the equipment will operate to the user's satisfaction.

Before installing this equipment, users should ensure that it is permissible to be connected to the facilities of the local telecommunications company. The equipment must also be installed using an acceptable method of connection. The customer should be aware that compliance with the above conditions may not prevent degradation of service in some situations.

Repairs to certified equipment should be coordinated by a representative designated by the supplier. Any repairs or alterations made by the user to this equipment, or equipment malfunctions, may give the telecommunications company to request the user to disconnect the equipment.

Users should ensure for their own protection that the electrical ground connections of the power utility, telephone lines and internal metallic water pipe system, if present, are connected together. This precaution may be particularly important in rural areas.

**Caution:** Users should not attempt to make such connections themselves but should contact appropriate electric inspection authority, or electrician, as appropriate.

### Ringer Equivalence Number Notice:

The **Ringer Equivalence Number (REN)** assigned to each terminal device provides an indication of the maximum number of terminals allowed to be connected to a telephone interface. The termination on an interface may consist of any combination of devices subject only to the requirement that the sum of the Ringer Equivalence Numbers of all the devices does not exceed 5.

### Industrie Canada

**AVIS:** l'étiquette d'Industrie Canada identifie le matériel homologué. Cette étiquette certifie que le matériel est conforme aux normes de protection, d'exploitation et de sécurité des réseaux de télécommunications, comme le prescrivent les documents concernant les exigences techniques relatives au matériel terminal. Le Ministère n'assure toutefois pas que le matériel fonctionnera à la satisfaction de l'utilisateur.

Avant d'installer ce matériel, l'utilisateur doit s'assurer qu'il est permis de le raccorder aux installations de l'entreprise locale de télécommunication. Le matériel doit également être installé en suivant une méthode acceptée de raccordement. L'abonné ne doit pas oublier qu'il est possible que la conformité aux conditions énoncées ci-dessus n'empêche pas la dégradation du service dans certaines situations.

Les réparations de matériel homologué doivent être coordonnées par un représentant désigné par le fournisseur. L'entreprise de télécommunications peut demander à l'utilisateur de débrancher un appareil à la suite de réparations ou de modifications effectuées par l'utilisateur ou à cause de mauvais fonctionnement.

Pour sa propre protection, l'utilisateur doit s'assurer que tous les fils de mise à la terre de la source d'énergie électrique, de lignes téléphoniques et des canalisations d'eau métalliques, s'il y en a, sont raccordés ensemble. Cette précaution est particulièrement importante dans les régions rurales.

**Avertissement :** L'utilisateur ne doit pas tenter de faire ces raccordements lui-même; il doit avoir recours à un service d'inspection des installations électriques, ou à un électricien, selon le cas.

**AVIS :** L'**indice d'équivalence de la sonnerie (IES)** assigné à chaque dispositif terminal indique le nombre maximal de terminaux qui peuvent être raccordés à une interface. La terminaison d'une interface téléphonique peut consister en une combinaison de quelques dispositifs, à la seule condition que la somme d'indices d'équivalence de la sonnerie de tous les dispositifs n'excède pas 5.

## LIMITATIONS STATEMENT

### WARNING

#### THE LIMITATIONS OF THIS ALARM SYSTEM

While this System is an advanced design security system, it does not offer guaranteed protection against burglary, fire or other emergency. Any alarm system, whether commercial or residential, is subject to compromise or failure to warn for a variety of reasons. For example:

- Intruders may gain access through unprotected openings or have the technical sophistication to bypass an alarm sensor or disconnect an alarm warning device.
- Intrusion detectors (e.g., passive infrared detectors), smoke detectors, and many other sensing devices will not work without power. Battery-operated devices will not work without batteries, with dead batteries, or if the batteries are not put in properly. Devices powered solely by AC will not work if their AC power supply is cut off for any reason, however briefly.
- Signals sent by wireless transmitters may be blocked or reflected by metal before they reach the alarm receiver. Even if the signal path has been recently checked during a weekly test, blockage can occur if a metal object is moved into the path.
- A user may not be able to reach a panic or emergency button quickly enough.
- While smoke detectors have played a key role in reducing residential fire deaths in the United States, they may not activate or provide early warning for a variety of reasons in as many as 35% of all fires, according to data published by the Federal Emergency Management Agency. Some of the reasons smoke detectors used in conjunction with this System may not work are as follows. Smoke detectors may have been improperly installed and positioned. Smoke detectors may not sense fires that start where smoke cannot reach the detectors, such as in chimneys, in walls, or roofs, or on the other side of closed doors. Smoke detectors also may not sense a fire on another level of a residence or building. A second floor detector, for example, may not sense a first floor or basement fire. Finally, smoke detectors have sensing limitations. No smoke detector can sense every kind of fire every time. In general, detectors may not always warn about fires caused by carelessness and safety hazards like smoking in bed, violent explosions, escaping gas, improper storage of flammable materials, overloaded electrical circuits, children playing with matches, or arson. Depending on the nature of the fire and/or location of the smoke detectors, the detector, even if it operates as anticipated, may not provide sufficient warning to allow all occupants to escape in time to prevent injury or death.
- Passive Infrared Motion Detectors can only detect intrusion within the designed ranges as diagrammed in their installation manual. Passive Infrared Detectors do not provide volumetric area protection. They do create multiple beams of protection, and intrusion can only be detected in unobstructed areas covered by those beams. They cannot detect motion or intrusion that takes place behind walls, ceilings, floors, closed doors, glass partitions, glass doors, or windows. Mechanical tampering, masking, painting or spraying of any material on the mirrors, windows or any part of the optical system can reduce their detection ability. Passive Infrared Detectors sense changes in temperature; however, as the ambient temperature of the protected area approaches the temperature range of 90° to 105°F (32° to 40°C), the detection performance can decrease.
- Alarm warning devices such as sirens, bells or horns may not alert people or wake up sleepers if they are located on the other side of closed or partly open doors. If warning devices are located on a different level of the residence from the bedrooms, then they are less likely to waken or alert people inside the bedrooms. Even persons who are awake may not hear the warning if the alarm is muffled by noise from a stereo, radio, air conditioner or other appliance, or by passing traffic. Finally, alarm warning devices, however loud, may not warn hearing-impaired people.
- Telephone lines needed to transmit alarm signals from a premises to a central monitoring station may be out of service or temporarily out of service. Telephone lines are also subject to compromise by sophisticated intruders.
- Even if the system responds to the emergency as intended, however, occupants may have insufficient time to protect themselves from the emergency situation. In the case of a monitored alarm system, authorities may not respond appropriately.
- This equipment, like other electrical devices, is subject to component failure. Even though this equipment is designed to last as long as 10 years, the electronic components could fail at any time.

The most common cause of an alarm system not functioning when an intrusion or fire occurs is inadequate maintenance. This alarm system should be tested weekly to make sure all sensors and transmitters are working properly. The security keypad (and remote keypad) should be tested as well.

Wireless transmitters (used in some systems) are designed to provide long battery life under normal operating conditions. Longevity of batteries may be as much as 4 to 7 years, depending on the environment, usage, and the specific wireless device being used. External factors such as humidity, high or low temperatures, as well as large swings in temperature, may all reduce the actual battery life in a given installation. This wireless system, however, can identify a true low-battery situation, thus allowing time to arrange a change of battery to maintain protection for that given point within the system.

Installing an alarm system may make the owner eligible for a lower insurance rate, but an alarm system is not a substitute for insurance. Homeowners, property owners and renters should continue to act prudently in protecting themselves and continue to insure their lives and property.

We continue to develop new and improved protection devices. Users of alarm systems owe it to themselves and their loved ones to learn about these developments.

## CONTACTING TECHNICAL SUPPORT

**PLEASE, before you call Technical Support, be sure you:**

- READ THE INSTRUCTIONS!
- Check all wiring connections.
- Determine that the power supply and/or backup battery are supplying proper voltages.
- Verify your programming information where applicable.
- Note the proper model number of this product, and the version level (if known) along with any documentation that came with the product.
- Note your Honeywell customer number and/or company name.

Having this information handy will make it easier for us to serve you quickly and effectively.

Technical Support: ..... 1-800-645-7492 (8 a.m.-10 p.m. E.S.T.)  
MyWebTech: ..... <http://www.honeywell.com/security/hsc/resources/MyWebTech>

# WORKSHEET for \*56 ZONE PROGRAMMING

(VISTA-15P supports up to 32 zones: 1-6, 9-34, 49-56) [default shown in brackets]

Zone	Zn Type	Part.	Report	Hardwire Type	Resp. Time	Location	
1	[09]	[1]		[EOL]	[1]		
2	[01]	[1]		[EOL]	[1]		
3	[03]	[1]		[EOL]	[1]		
4	[03]	[1]		[EOL]	[1]		
5	[03]	[1]		[EOL]	[1]		
6	[03]	[1]		[EOL]	[1]		
7	[03]	[1]		[EOL]	[1]		
8	[03]	[1]		[EOL]	[1]		
Zone	Zn Type	Part.	Report	Input Type	Loop	Serial No.	Location
9							
10							
11							
12							
13							
14							
15							
16							
17							
18							
19							
20							
21							
22							
23							
24							
25							
26							
27							
28							
29							
30							
31							
32							
33							
34							
35							
36							
37							
38							
39							
40							
41							
42							
43							
44							
45							
46							
47							
48							
49		[1]		[BR]			
50		[1]		[BR]			
51		[1]		[BR]			
52		[1]		[BR]			
53		[1]		[BR]			
54		[1]		[BR]			
55		[1]		[BR]			
56		[1]		[BR]			
57		[1]		[BR]			
58		[1]		[BR]			
59		[1]		[BR]			
60		[1]		[BR]			
61		[1]		[BR]			
62		[1]		[BR]			
63		[1]		[BR]			
64		[1]		[BR]			
95	[00]	N/A**		N/A	N/A	N/A	keypad [1] / [*]
96	[00]	N/A**		N/A	N/A	N/A	keypad [3] / [#]
99	[06]	N/A**		N/A	N/A	N/A	keypad [*] / [#]

**NOTES:**

Zone Type: see chart \*56 Zone Programming Menu mode section.

Report Code: enabled if first digit is a non-zero number.

Hardwire Type (zns 2-8):  
 0 = EOL    3 = ZD  
 1 = NC     4 = DB  
 2 = NO

Input Type:  
 2 = AW (zones 9-48)  
 3 = RF (zones 9-48)  
 4 = UR (zones 9-48)  
 5 = BR (zones 49-64)

**NOTE:** Zones 9-16 not available if zone doubling enabled.

Response Time:  
 0 = 10msec  
 1 = 350msec  
 2 = 700msec  
 3 = 1.2 sec

**Reserved Zones**

91 = addressable device report enable/disable default zone type = [05].

92 = Duress report enable/disable

\*\* Emergency key zones 95, 96, and 99 report the partition of the keypad used to activate the emergency zones.

## WORKSHEET for \*57 FUNCTION KEY PROGRAMMING

Option	Function	A			B			C			D			Comments
		P1	P2	com	P1	P2	com	P1	P2	com	P1	P2	com	
01	Paging													
02	Time Display													
03	Arm AWAY													
04	Arm STAY													
05	Arm NIGHT-STAY													
06	Step Arming													
07	Device Activation													Device:
08	Comm. Test													
09	Macro Key 1													Assign each macro key to only a single partition. †
10	Macro Key 2													Assign each macro key to only a single partition. †
11	Macro Key 3													Assign each macro key to only a single partition. †
12	Macro Key 4													Assign each macro key to only a single partition. †
00	Emergency Keys:			zone 95			zone 99			zone 96			paging	
	Personal Emergency												n/a	
	Silent Alarm												n/a	
	Audible Alarm												n/a	
	Fire												n/a	

Emergency Keys: A = paired keys [1] / [\*] (zone 95); B = paired keys [\*] / [#] (zone 99); C = paired keys [3] / [#] (zone 96)  
 † There are only four macros system-wide.

## WORKSHEET for \*79 OUTPUT RELAY/POWERLINE CARRIER DEVICE PROGRAMMING

Applicable only if Relays and/or Powerline Carrier (X-10) Devices are to be used.

### \*79 RELAY/POWERLINE CARRIER (X-10) DEVICE MAPPING (Must program before using \*80)

Output No.	OUTPUT TYPE				Description
	Relay		X10		
	Module Addr.	Pos (1-4)	Unit No.		
01					
02					
03					
04					
05					
06					
07					
08					

Output No.	OUTPUT TYPE (09-16 apply to VISTA-20P only)				Description
	Relay		X10		
	Module Addr.	Pos (1-4)	Unit No.		
09					
10					
11					
12					
13					
14					
15					
16					
17					On-Board Trigger 1 norm output =
18					On-Board Trigger 2 norm output =

## WORKSHEET for \*81 ZONE LIST PROGRAMMING

Fill in the required data on the worksheet below and follow the procedure in the installation manual as you enter the data during the displays and prompts that appear in sequence.

**NOTE:** Record desired zone numbers below, noting that a list may include *any* or *all* of system's zone numbers.

List No.	Used For...	Contains These Zones...
01	General Purpose (GP)	
02	General Purpose	
03	Chime-by-Zone or GP	(see field *26 for Chime-by-Zone option)
04	Cross Zones or GP	(see field *85 for Cross Zone Timer option)
05	Night-Stay Zones or GP	
06	Dial Delay Disable or GP	V20PSIA/V15PSIA; see field *50 for Dial Delay Disable option
07	Unlimited Reports or GP	V20PSIA/V15PSIA; see field *93 for Unlimited Reports option
08	General Purpose	
09	Zones activating pager 1	
10	Zones activating pager 2	
11	Zones activating pager 3	(VISTA-20P)
12	Zones activating pager 4	(VISTA-20P)

# WORKSHEET for \*80 OUTPUT FUNCTION PROGRAMMING

Fill in the required data on the worksheet below and follow the programming procedure in the installation manual as you enter the data during the displays and prompts that appear in sequence.

- Notes:** 1. For Relays, 4229 and 4204 devices are programmed in \*79, \*80, and \*81 modes.  
 2. For Powerline Carrier devices (plcd), field \*27 must be programmed with a House Code.  
 3. Tamperers of expansion units cannot be used to operate devices.

Output Function Number (V20P=1-48) (V15P=1-24)	Activation Type and Detail			Partition Number (P) (if using ZT trig) 0 = any 1 = partition 1 2 = partition 2 3 = common	Event (for zone list/activated by)		Action 0 = off 1 = close 2 secs 2 = stay closed 3 = pulse 4 = toggle 5 = duration 1†† 6 = duration 2††	Output Number V20P=1-18 V15P=1-8, 17, 18	Device Type R = relay T = trigger X = X10
	Activated by 0=delete 1=zn list 2=zn type 3=zn no.	Zone List (ZL) 1-8 = list	Zone Type (ZT) (see table below)		Zone No. (ZN) 00=none V20P: 01-64 V15P: 01-06, 09-34, 49-56	By Zone List			
1									
2									
3									
4									
5									
6									
7									
8									
9									
10									
11									
12									
13									
14									
15									
16									
17									
18									
19									
20									
21									
22									
23									
24									
25									
26									
27									
28									
29									
30									
31									
32									
33									
34									
35									
36									
37									
38									
39									
40									
41									
42									
43									
44									
45									
46									
47									
48									

**ZONE TYPE/SYSTEM OPERATION – Choices for Zone Types are:**

- 00 = Not Used
- 01 = Entry/Exit#1
- 02 = Entry/Exit#2
- 03 = Perimeter
- 04 = Interior Follower
- 05 = Trouble Day/Alarm Night
- 06 = 24 Hr Silent
- 07 = 24 Hr Audible
- 08 = 24 Hr Aux
- 09 = Fire
- 10 = Interior w/Delay
- 12 = Monitor Zone
- 14 = Carbon Monoxide§§
- 16 = Fire w/Verification
- 23 = No Alarm Response
- 24 = Silent Burglary
- 77 = Keypad
- 81 = AAV Monitor Zone
- 90-91 = Configurable

§§ when used with an output function, the carbon monoxide zone type activates only upon CO alarms. Does not activate for trouble conditions.

**Choices for System Operation are:**

- 20 = Arming–Stay
- 21 = Arming–Away
- 22 = Disarming (Code + OFF)
- 31 = End of Exit Time
- 32 = Start of Entry Time
- 33 = Any Burglary Alarm
- 36 = \*\*At Bell Timeout\*\*
- 38 = Chime
- 39 = Any Fire Alarm
- 40 = Bypassing
- 41 = \*\*AC Power Failure
- 42 = \*\*System Battery Low
- 43 = Communication Failure
- 52 = Kissoff
- 54 = Fire Zone Reset
- 58 = Duress
- 60 = AAV Trigger
- 61 = AVS/GSMV4G session begin §
- 62 = AVS/GSMV4G session end §
- 66 = Function key†
- 67 = Bell Failure
- 68 = TELCO Line Fault
- 78 = Keypad red LED†††
- 79 = Keypad green LED†††

**Note:** In normal operation mode:  
 Code + # + 7 + NN Key Entry **starts** Device  
 Code + # + 8 + NN Key Entry **stops** Device

\*\* Use 0 (any) for Partition No. (P) entry.  
 \*\*\* Or at Disarming, whichever occurs earlier.  
 † Use \*57 Menu mode to assign the function key.  
 †† Duration is set in program field \*177.  
 ††† Device action not used for these choices.  
 § automatically set when appropriate AVS Quick Command performed.

# WORKSHEET for SCHEDULES

(installer code + [#] + [6] [4]; master code can only access schedules 01-16 for VISTA-20P, 01-04 for VISTA-15P, and events 00-07 for both controls; VISTA-15P supports up to 8 schedules, VISTA-20P supports up to 32 schedules)

No.	Event (see list below)	Device No. for "01" events: enter 01-18	Group No. for "02" events: enter 1-8	Partition for "04-06" events: enter 1, 2, or 3 (VISTA-20P)	Start Time/ Days	Stop Time/ Days	Repeat (1-4)	Random (yes/no)
01								
02								
03								
04								
05								
06								
07								
08								
09								
10								
11								
12								
13								
14								
15								
16								
17								
18								
19								
20								
21								
22								
23								
24								
25								
26								
27								
28								
29								
30								
31								
32								

Events: Master/Installer  
 00 = clear event  
 01 = device on/off  
 02 = user access  
 03 = latch key report  
 04 = forced STAY arm  
 05 = forced AWAY arm  
 06 = auto disarm  
 07 = display "reminder"  
 Installer Only  
 10 = display custom words 8-10  
 11 = periodic test report

Repeat Options: 0 = none; 1 = repeat weekly; 2 = repeat every other week; 3 = repeat every third week; 4 = repeat every fourth week

## TABLE OF DEVICE ADDRESSES

This Device	Uses Address	Reports as ††	Enabled By...
RF Receiver	00	100	*56 zone programming: input device type entry
AUI 1 (touchscreen)	01	n/a	automatic if AUI enable field *189 enabled for AUI 1
AUI 2 (touchscreen)	02	n/a	automatic if AUI enable field *189 enabled for AUI 2
AUI 3 (touchscreen) (V20P)	05	n/a	automatic if AUI enable field *189 enabled for AUI 3
AUI 4 (touchscreen) (V20P)	06	n/a	automatic if AUI enable field *189 enabled for AUI 4
Communications Device (LRR)	03	103	automatic if communications device enabled in menu mode *29
4286 Voice Module	04	104	automatic if phone module access code field *28 enabled
Zone Expanders (4219/4229):			*56 zone programming: input device type entry, then:
module 1 (for zones 09 - 16)	07	107	automatic if zone no. 9-16 entered as AW type or relay assigned
module 2 (for zones 17 - 24)	08	108	automatic if zone no. 17-24 entered as AW type or relay assigned
module 3 (for zones 25 - 32)	09 (V20P)	109	automatic if zone no. 25-32 entered as AW type or relay assigned
module 4 (for zones 33 - 40)	10 (V20P)	110	automatic if zone no. 33-40 entered as AW type or relay assigned
module 5 (for zones 41 - 48)	11 (V20P)	111	automatic if zone no. 41-48 entered as AW type or relay assigned
Relay Modules (4204):			*79 output device programming: device address prompt:
module 1	12	112	entered at device address prompt
module 2	13	113	entered at device address prompt
module 3	14 (V20P)	114	entered at device address prompt
module 4	15 (V20P)	115	entered at device address prompt
Keypads:			data field programming as listed below:
keypad 1	16	n/a	always enabled, all sounds enabled.
keypad 2	17	n/a	data field *190
keypad 3	18	n/a	data field *191
keypad 4	19	n/a	data field *192
keypad 5	20	n/a	data field *193
keypad 6	21	n/a	data field *194
keypad 7	22	n/a	data field *195
keypad 8	23	n/a	data field *196
RIS Communication	25	n/a	automatic if Remote Interactive Services enabled in field *91
5800TM Module	28	n/a	automatic

†† Addressable devices are identified by "1" plus the device address when reporting. Enter report code for zone 91 to enable device reporting (default = enabled). See field \*199 for addressable device (ECP) 3-digit/2-digit identification keypad display options. AUI devices are not supervised and therefore do not report.

# 5800 SERIES TRANSMITTER INPUT LOOP IDENTIFICATION

All of the transmitters illustrated have one or more unique factory assigned input (loop) ID numbers. Each of the inputs requires its own programming zone (e.g., a 5804's four inputs require four programming zones). For information on any transmitter not shown, refer to the instructions accompanying that transmitter for details regarding loop numbers, etc.

**UL NOTE:** The following transmitters are not intended for use in UL installations: 5804BD, 5814, 5816TEMP, 5819, 5819WHS and 5819BRS.  
The 5827BD and 5800TM can be used in UL Listed Residential Burglar installations.

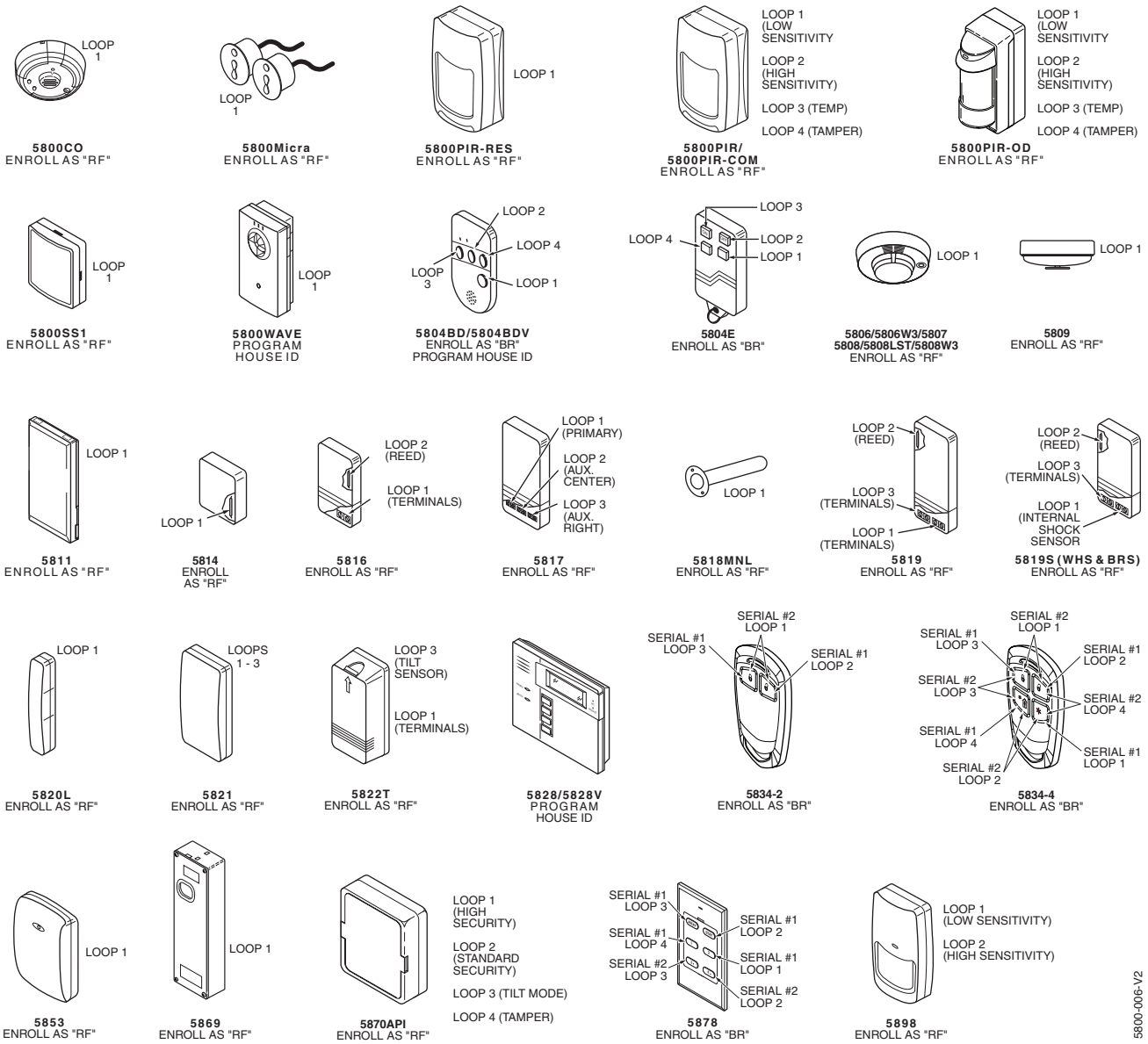

**WARRANTY INFORMATION**  
For the latest warranty information, please go to:  
[www.honeywell.com/security/hsc/resources/wa](http://www.honeywell.com/security/hsc/resources/wa)

## Honeywell

2 Corporate Center Drive, Suite 100  
P.O. Box 9040, Melville, NY 11747  
Copyright © 2003 Honeywell International Inc.  
[www.honeywell.com/security](http://www.honeywell.com/security)



K5305-1PRV8 5/11 Rev. C

5800-006-V2